



λmini EVO User Manual

User Manual
For the Lambda mini Evo Laser
Version: 2.1.4
Date: March, 2023

This document is protected by copyright. Do not copy or publish this document or parts of it without written permission of RGB Lasersystems GmbH.

Product specifications and descriptions in this manual are subject to change without notice. RGB Lasersystems GmbH will not be responsible for errors and omissions in this manual or for direct or incidental damages in connection with the use of this device or information.

© 2023 RGB Lasersystems GmbH
Donaupark 13
93309 Kelheim
Germany

Telephone: +49 9441 1750 33 – 0
Website: <http://www.rgb-lasersystems.com>
E-Mail: sales@rgb-photonics.com

Contents

Contents	i
1 Laser Safety Precautions	1
2 Introduction	3
2.1 Product Overview	3
2.2 Package Contents	3
3 Installation and Operation	5
3.1 Precautions	5
3.2 Laser operation	5
3.3 Troubleshooting	6
4 Computer Control	9
4.1 Ltune Laser Control Software	9
4.2 Serial Communication	10
5 Specifications	15
5.1 General Specifications	15
5.2 Beam Specifications	15
5.3 Electrical Specifications	15
5.4 Mechanical specifications	16
6 Certifications and Compliance	17
Acronyms	21

1 Laser Safety Precautions



CAUTION: This device emits visible and invisible **LASER** radiation. Avoid exposure to the beam!

Lasers emit visible and invisible radiation that may cause damages to material and person, mainly by thermal effect. Radiation entering the human eye can damage the retina, which leads to partial or total loss of vision. The damage can occur without particular perception or sensation of pain.

Please consider all protection and safety regulations while handling laser systems. Always use laser protection glasses for the specified wavelength range.

Never direct the laser towards people. Keep the laser beam away from reflective surfaces in order to avoid uncontrolled reflections. Do not mount the laser at eye level.

It is your responsibility to guarantee the laser safety as required by law. Please pay attention to safety regulations DIN EN 61010-1, DIN EN 60825-1:2003-10 and DIN EN 60950 when operating the laser.

The Lambda mini Evo series is specified by the United States National [Center of Device and Radiological Health \(CDRH\)](#) as a class 3b laser product. Visible and invisible laser radiation is emitted.

Modifications that may affect any aspect of the product's performance or intended functions will require re-certification and re-identification of the product in accordance with the provisions of 21CFR 1040.10 and 1040.11.

Lambda mini Evo laser modules are marked with a warning label as shown on the right.



2 Introduction

2.1 Product Overview

The Lambda mini remarkably small design, it includes not only the laser diode and precision collimating optics, but also the laser controller and power supply via USB. All that is needed for operating and controlling the laser is a simple [Universal Serial Bus \(USB\)](#) cable connected to a PC. Its compact size makes the Lambda mini an ideal choice as a precision light source for space-limited application. The Lambda mini Evo emits a free collimated TEM_{00} laser beam. Also available is the Lambda mini Fiber, which couples the laser beam into an optical fiber.

Features:

- Remarkably small design
- Optical output powers up to 75 mW
- Powered by USB (no extra power adapter or cable required)
- Horizontal and vertical mounting options for various rail systems
- Produced in clean-room atmosphere
- Temperature monitoring
- Professional housing
- USB interface
- Ltune laser control software included
- Excellent value for money

2.2 Package Contents

Laser module

In order to provide the best beam quality only high quality optical components are used within the laser module.

Cable

A standard Mini [USB](#) cable is used for connecting the laser to a computer or power supply. The length of the cable is 1.5 m (5 ft).

Software

Our website includes the download of the Windows application software Ltune for configuring and controlling the laser system as well as this manual as a Portable Document Format (PDF) file.



3 Installation and Operation

3.1 Precautions

- **Take care of all laser safety instructions** as described in [chapter 1](#). Always wear laser protection glasses for the specified wavelength range.
- Consider regulations for [electrostatic discharge \(ESD\)](#).
- Do not open the laser head. Opening the case voids the warranty and may cause uncontrolled laser radiation.
- Always mount the laser module securely and pay attention to sufficient heat dissipation.
- **Do not reflect the laser beam back into the laser head.** The laser diode could be damaged if more than 2 % of the emitted power is reflected back into it. Carefully check all mirroring surfaces of your optical setup for possible back reflections. If required, use a suitable optical insulator.
- Do not exceed the environment conditions specified in [chapter 5](#).

3.2 Laser operation

The Lambda mini Evo laser module is controlled via [USB](#) and operated in constant [continuous wave \(CW\)](#) mode without an external control voltage.



1. In order to set up the laser module for operation, please:
2. Install the Ltune laser control software including the device driver on a Windows [Personal Computer \(PC\)](#).
3. Connect the Lambda mini laser module to the computer using the supplied [USB](#) cable. You can also use any other standard Mini [USB](#) cable.
4. After a quick self-test the green POWER [LED](#) should be lit continuously.
5. Start the Ltune application on the computer. The laser module should be detected and initialized automatically.
6. Make sure the interlock connector is closed.

- In Ltune, set the desired output power and click on the power on/off button. The laser will start with a 5 s delay (as required by laser safety regulations). Once the laser is active, the EMISSION indicator is lit.

The laser can be switched off remotely from the computer or by simply disconnecting the [USB](#) cable.

Status Indicators

The laser module includes two [light emitting diodes \(LEDs\)](#) to indicate the laser status:

LED	Status	Description
POWER 	On	Power supply connected, self-test successful
	Off	Powersupply not connected
	Flashing	Error
EMISSION 	On	Laser active, emission possible (depending on selected output power)
	Off	Laser inactive
	Flashing	5 second delay before activating laser

Interlock

The interlock connector next to the [USB](#) port on the device can be used to enable or disable laser emission. You can either use the supplied jumper to close the contacts or attach a custom switch. If the two pins are not connected, the laser is turned off and no emission is possible. When the two pins are connected again, the laser emissions starts after a 5 s delay, if the laser is remotely turned on and an emission power larger than zero is selected.

3.3 Troubleshooting

If the device is detected by Ltune, but there is no laser emission: Please make sure that these conditions are met:

- The green [LED](#) is lit continuously (if not, please check the bottom of the Ltune window for error messages).
- The interlock connector is closed.
- The power on/off button in Ltune is turned on
- An output power larger than zero is selected.

If the device is not detected when Ltune is started:

First of all, please disconnect the laser from the computer, restart the computer, connect the laser again and start the Ltune software.

If the laser is still not found: The Ltune software communicates with the laser using a "virtual serial port". If the driver is installed correctly, it should show up in the Windows Device Manager. You can open the device manager by clicking Start -> Control Panel (-> Performance and Maintenance) -> System -> Hardware -> Device Manager.

In the device manager, please open the "Ports (COM & LPT)" subtree. One of the COM ports listed there should belong to your laser. If you right-click on the correct item, choose "Properties" and then the "Driver" tab page, it should read: "Driver Provider: FTDI" and "Driver Version: 2.8.14.0" (or later). If this is the case, please start Ltune and try to select this COM port manually by unchecking "Auto-scan all serial ports" in "Device setup".

If your laser is not listed in the device manager or marked with an exclamation or question mark, please try the following:

1. Disconnect your laser from the computer and from power supply.
2. Download <http://www.ftdichip.com/Resources/Utilities/FTClean.zip> and run this tool to remove the FTDI driver from your computer.
3. Reinstall Ltune from the our website.
4. Reconnect the laser to the computer.
5. Start Ltune.

4 Computer Control

The Lambda mini Evo uses a [USB](#) interface for remote control. The laser can be controlled with

- The Windows application software Ltune (included) or
- Custom user software via serial communication.

4.1 Ltune Laser Control Software

The Lambda mini laser can be configured and controlled using the Ltune software for Windows. The software features:

- Output power adjustment
- Display of the laser status, configuration and operating hours
- Temperature display

To install the software, simply run the setup file from the [our website](#).

The setup package then installs the application software and the device driver. For the operating system to properly recognize the de software first before attaching the device.

The software is tested with 32 and 64 bit versions of Windows 8, 7, Vista and XP. It requires the Microsoft .NET framework version 3.5 or 4.0, which is already installed on most PCs. If this framework is not installed, the setup package asks you to install it first. You can find the setup file for the .NET framework on the Microsoft's website.

Please note that you need at least version 3.5 of the .NET framework.

After the software is installed, please connect your Lambda mini laser to a [USB 2.0](#) port on the computer. You can use the provided [USB](#) cable or almost any other Mini-USB cable.

If not already installed wait until the laser driver is completely installed. The laser should be detected automatically. If not you can click on device setup to start a new search.

Please note that you can change the user interface to a more compact view by clicking the small button next to "Device Properties"

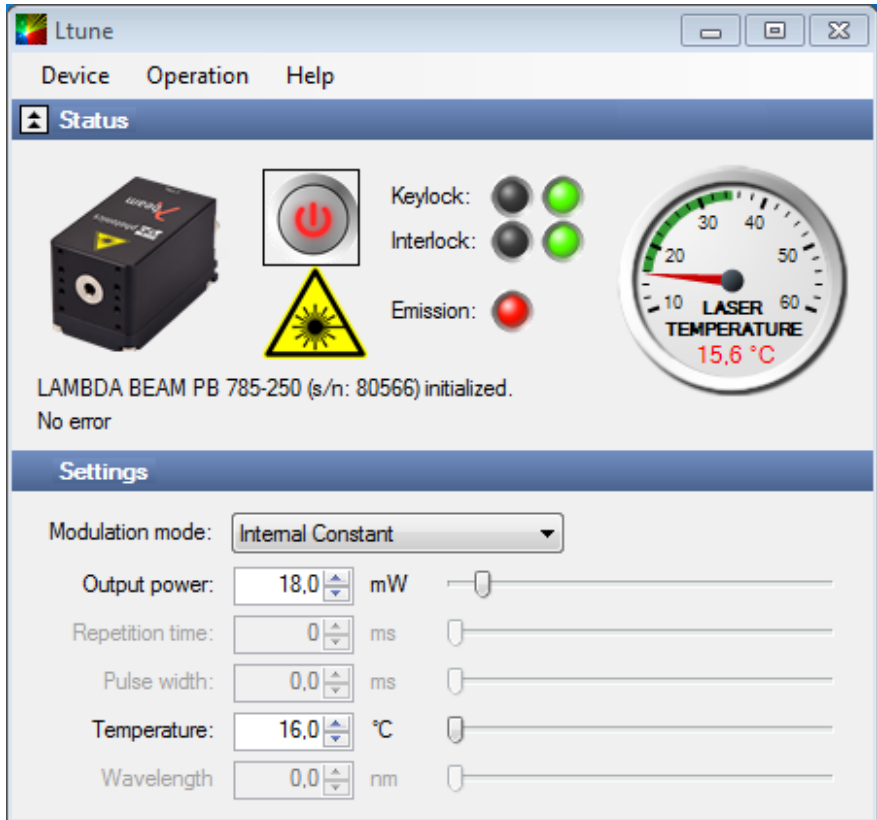

Figure 4.1: Ltunes GUI

Please also note that the Ltune software works with different laser modules and therefore provides support for some features that are not included in the Lambda mini Evo .

4.2 Serial Communication

Overview

When the laser controller is connected to a [PC](#) and the device driver installed, it shows up as a virtual COM port and can be accessed from almost any programming language. A detailed description of the commands and queries is given in the following section.

The command settings are not stored when the system is powered down.

Communication protocol

The commands and queries have the following syntax:

Commands: `command=<parameter value>`

A command changes an actual setting. The syntax is the command, followed by an equal sign and the parameter value. The parameter value is the value to be set. Commands have no return value.

Queries: `query?`

A query returns information about the device or the value of a setting. The syntax is the query, followed by a question mark. Queries have no parameter value. A query delivers a return value.

Return Code

A return code gives information about the processing of a command or query. There is always a space character between the return code and the result. The return codes are listed in [table 4.1](#).

Table 4.1: Return Codes

Code	Name	Description 0
	COMMAND_SUCCESS	Command successful
1	COMMAND_INVALID	Command invalid
2	PARAMETER_ERROR	Wrong numbers of parameters
3	VALUE_INVALID	Parameter value is out of range
4	CODE_INVALID	Unlocking code is wrong
5	DEVICE_LOCKED	Device is locked for this command
6	FUNCTION_NOT_SUPPORTED	This function is not supported
7	COM_TIME_OUT	Timeout while reading command (60 s)
8	VALUE_NOT_AVAILABLE	This value is currently not available

All commands and queries and all responses from the device are followed by the line termination string "\r\n" (carriage return & line feed). All instructions have to be written in capital letters.

Initializing the serial communication

The Lambda mini Evo uses the communication settings displayed in [table 4.2](#).

Table 4.2: Lambda mini communication settings

Baud rate	57600
Parity	None
Data bits	8
Stop bits	1

Turning the laser on and off

This command is used to set the and read the "Laser Enable" request. The laser can only be activated if the key switch is in the ON position and the interlock is closed.

Table 4.3: Laser Enable commands

Command/ Query	Parameter value	Return code	Return value
O=	0: Delete Enable Request 1: Set Enable Request	COMMAND_SUCCESS PARAMETER_ERROR	-
O?	-	COMMAND_SUCCESS	0: Enable Request not set 1: Enable Request set

Temperature settings

The Lambda mini Evo monitors the operating temperature. If it exceeds the permitted temperature range, the laser is turned off to prevent damage to the module. The commands for temperature settings are listed in [table 4.4](#)

Table 4.4: commands for temperature settings

Command/ Query	Parameter value	Return code	Return value
T?	-	COMMAND_SUCCESS VALUE_NOT_AVAILABLE	Current temperature in °C
LTN?	-	COMMAND_SUCCESS	Lowest operating temperature in °C
LTP?	-	COMMAND_SUCCESS	Highest operating temperature in °C

CW mode

The Lambda mini laser is operated in CW mode at constant power between 0 % and 100 % of the maximum output power.

Table 4.5: CW mode commands

Command/ Query	Parameter value	Return code	Return value
P?	-	COMMAND_SUCCESS	Output power in mW
P=	Output power in mW (value between 0 and LP)	COMMAND_SUCCESS VALUE_INVALID	-
LP?	-	COMMAND_SUCCESS	Maximum output power in mW

Status and device information

The query S? gets the actual status of the laser system including information about the Enable Request, the interlock and active errors.

The query R? returns the operation hours of the laser system. The operation time is the accumulated time during which the laser was active (red LED on).

Table 4.6: Status and device information commands

Query	Parameter value	Return code	Returnvalue
S?	-	COMMAND_SUCCESS	Current device status (see table below)
R?	-	COMMAND_SUCCESS	Total operating hours [hhhh:mm]
DM?	-	COMMAND_SUCCESS	Manufacturer
DT?	-	COMMAND_SUCCESS	Device name
DS?	-	COMMAND_SUCCESS	Serial number
D0?	-	COMMAND_SUCCESS	Software version
DW?	-	COMMAND_SUCCESS	Emission wavelength in nm
DF?	-	COMMAND_SUCCESS	Available features (reserved for future use)
DC?	-	COMMAND_SUCCESS	ACC = active current control (ACC) APC = active Power control (APC)

The result of the status request S? is a bit-wise combination of the values listed in :

Table 4.7: status request commands

Code	Mnemonic	Description
0x01	LASER_ON	Laser system in active, radiation can be emitted
0x02		(reserved)
0x04	INTERLOCK_OPEN	The interlock is open
0x08	ERROR	Error is active (error can be read with E? query)
0x10	TEMPERATURE_OK	Temperature of laser head is ok

Error status of the laser system

The query E? reads the actual active errors of the laser system.

Table 4.8: Error status of the laser system

Query	Parameter value	Return code	Return value
E?	-	COMMAND_SUCCESS	Error code (see table 4.9)

Possible error codes are shown in [table 4.9](#).

Table 4.9: error codes

Code	Mnemonic	Description
0x01	LASER_HEAD_OVERTEMP	Temperature of laser head is too high
0x02	LASER_HEAD_UNDERTEMP	Temperature of laser head is too low
0x04	TEMP_SENSOR_OPEN	Temperature-sensor connection is broken
0x08	TEMP_SENSOR_SHORTENED	Temperature sensor cable is shortened
0x40	LASER_OVERCURRENT	Current for laser head is too high
0x80	FATAL_INTERNAL_ERROR	Internal error (laser system cannot be activated)

5 Specifications

5.1 General Specifications

All specifications are based on stable environmental conditions.

Noise:	<2 % RMS
Power stability:	<2 % (10 h)
Warm-up time:	5 s
Drive mode:	ACC
Control mode:	Constant power, controlled via USB
CDRH Classification:	Class 3b
Weight:	40 g
ESD protection:	Level 4
Operating temperature:	0 °C to 45 °C (non-condensing)
Storage temperature:	−25 °C to 70 °C

5.2 Beam Specifications

Beam diameter:	1.1 mm × 2.2 mm to 1.2 mm × 2.8 mm (depending on wavelength)
Divergence:	<0.9 mrad
Spatial beam mode:	TEM ₀₀
Polarization:	>100/1 linear
Beam alignment:	<5 mrad an <0.1 mrad (compared to base mount)
Pointing stability (10 h):	<5 μrad/K

5.3 Electrical Specifications

Supply voltage: 5 V, powered via USB
 Supply current: up to 500 mA

5.4 Mechanical specifications

Length: 40.0 mm (1.57")
 Width: 25.0 mm (0.98")
 Height: 25.0 mm (0.98")

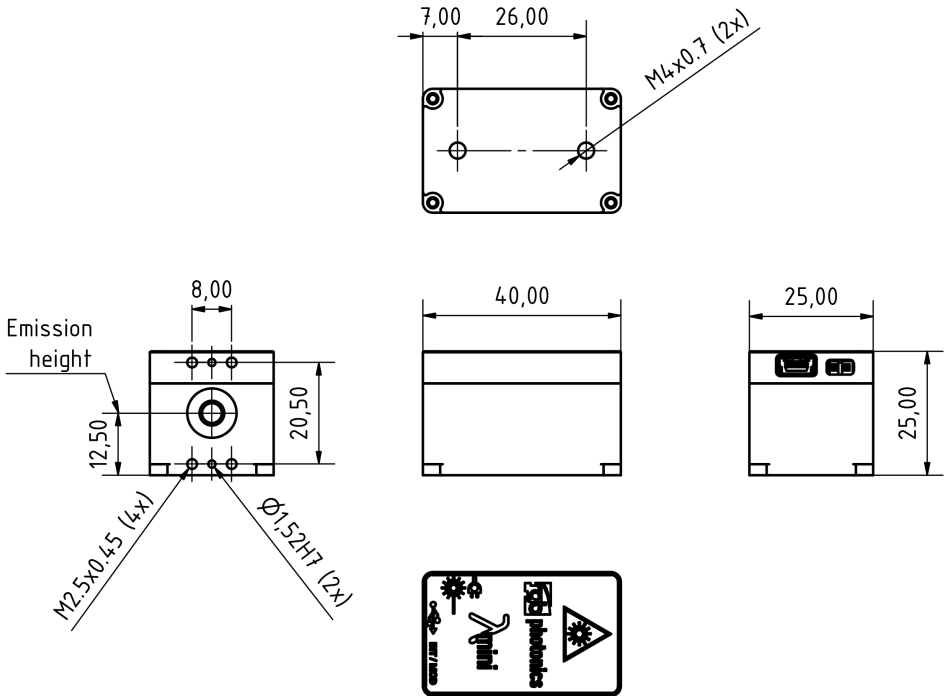

Figure 5.1: LambdaMini technical drawing

All dimensions in mm. 3D [computer-aided design \(CAD\)](#) files are available for download on www.rgb-photonics.com.

6 Certifications and Compliance

CE Declaration of Conformity

The manufacturer

RGB Lasersystems GmbH
Donaupark 13
93309 Kelheim



declares that the following product

Lambda mini Evo Version 1.0

complies with the following normative documents

EN6100-6-4: 2007 + A1:2011
EN6100-6-2: 2005

and therefore with the following EG requirements

Electromagnetic compability (2014/30/EU)

This declaration applies to all models of the above named product version, in case it will be used in the configuration of the tesst assembly.

A handwritten signature in blue ink, appearing to read 'Stefan Englbrecht', is written over a horizontal line.

Kelheim , November 19th, 2020

Stefan Englbrecht

FCC Compliance

This declaration applies to the following product:

Lambda mini Evo Version 1.0



This device complies with part 15 of the FCC Rules. Operation is subject to the following two conditions: (1) This device may not cause harmful interference, and (2) this device must accept any interference received, including interference that may cause undesired operation.

This equipment has been tested and found to comply with the limits for a Class A digital device, pursuant to Part 15 of the FCC Rules. These limits are designed to provide reasonable protection against harmful interference when the equipment is operated in a commercial environment. This equipment generates, uses and can radiate radio frequency energy and, if not installed and used in accordance with the instruction manual, may cause harmful interference to radio communications. Operation of this equipment in a residential area is likely to cause harmful interference in which case the user will be required to correct the interference at his own expense.

A handwritten signature in blue ink, appearing to read 'Stefan Englbrecht', is located in the bottom right corner of the document.

Kelheim , November 14th, 2020

Stefan Englbrecht

RoHS Declaration of Conformity

The manufacturer

RGB Lasersystems GmbH
Donaupark 13
93309 Kelheim

declares that the following product

Lambda mini Evo Version 1.0

contains no toxic substances which are specified in the

RoHS Directive 2011/65/EU.

The conformity to RoHS Directive 2011/65/EU is confirmed

This declaration applies to all models of the above named product version, in case it will be used in the configuration of the test assembly.



Kelheim, October 12th, 2020

Stefan Englbrecht

WEEE Directive

Please respect the **Waste Electrical and Electronic Equipment (WEEE)** directive 2012/19/EU and do not throw your RGB Lasersystems GmbH product into waste disposal but recycle it.



Acronyms

ACC	active current control. 13, 15
APC	active Power control. 13
CAD	computer-aided design. 16
CD-ROM	Compact Disc Read-Only Memory. 4, 7, 9
CDRH	Center of Device and Radiological Health. 1
CE	Conformité Européenne. 17
CW	continuous wave. 5
ESD	electrostatic discharge. 5
FCC	Federal Communications Commission. 18
LED	light emitting diode. 5, 6, 13
PC	Personal Computer. 5, 10
PDF	Portable Document Format. 4
RMS	root mean square. 15
RoHS	Restriction of the use of certain hazardous substances. 19
TEM	transverse electromagnetic mode. 3, 15
USB	Universal Serial Bus. 3, 4, 5, 6, 9, 15
WEEE	Waste Electrical and Electronic Equipment. 19



グローバルにネットワークを広げ、最先端の科学をお客様に提供

本社：〒134-0088 東京都江戸川区西葛西6-18-14 T.ビル

Tel. 03-3686-4711

営業所：〒532-0003 大阪府大阪市淀川区宮原4-1-46 新大阪北ビル

Tel. 06-6393-7411

URL : <https://www.tokyoinst.co.jp> Mail : sales@tokyoinst.co.jp



超高真空・極低温走査型プローブ顕微鏡
高速分光測定装置、クライオスタット



Nd:YAGレーザー、Ti:Sレーザー
OPOレーザー

- 本カタログに記載されている内容は、改良のため予告無く変更する場合があります。(製品の仕様、性能、価格などはカタログ発行当時のものです)
- 本カタログに記載されている内容の一部または全部を無断で転載することは禁止されています。
- 本カタログに記載されているメーカー名、製品名などは各社の商標または登録商標です。