

Laser Electronics

Tailored for your fs, ps, ns & CW lasers

Laser Diode Drivers 3

**Laser Power Supplies &
Control Units** 11

**Pockels Cell Drivers &
HV Power Supplies** 15

**Digital Delay
Generators** 25

**Crystal Ovens &
Thermocontrollers** 29

About Ekspla Electronics

EKSPLA's laser electronics product's design embodies 30+ years of experience in manufacturing and R&D of serial and custom laser systems. Up to date, laser electronics created by our team of enthusiastic engineers, has been the heart and soul of 30 000+ laser systems. 99%+ of sold products perform fails-free throughout a 10+ years' period under the most demanding conditions. Our exclusive area of expertise – tailored development and serial manufacturing of electronics for solid state, fiber and direct diode lasers. EKSPLA's experience includes custom adaptation and high-volume manufacturing for laser developers and manufacturers. Our clients – world-leading manufacturers of industrial, medical and scientific lasers whose systems are installed in 60+ countries and 80+ top universities worldwide. Ekspla laser electronics products are implemented in the world's most sophisticated laser systems developed for CERN, NASA, ELI, Max Planck Institutes, Cambridge University, Massachusetts Institute of Technology and other renowned scientific institutions.

History

EKSPLA was founded in 1992 by a small team of engineers united around the idea of making the most advanced lasers in the world. EKSPLA was an independent company with limited financial resources, but lots of creativity and deep technical knowledge. Naturally, the most advanced lasers needed top-notch electronics. At that time, there were no suppliers in the market who could deliver tailored laser electronics that met the highest standards. To meet EKSPLA's needs an in-house department for the design and manufacturing of laser electronics was established. As time progressed this team developed a wide range of quality products tailored to solve the main laser manufacturer's electronics challenges. At a certain point, accumulated know-how led to

the establishment of EKSPLA's new business branch focusing on development and manufacturing of tailored electronics for other solid state laser manufacturers. Expertise obtained over a decade-long of R&D resulted in fast turnaround times between the initial inquiry, the first prototype and the serial manufacturing stages, all while keeping the end product quality very high. Over time these qualities solidified EKSPLA's reputation in the market as an adaptive and reliable partner. Therefore, multiple notable femtosecond, picosecond, nanosecond and cw laser manufacturers began using EKSPLA's laser electronics. Despite some competition in laser segments, relationships with key OEM customers are well maintained and often last for over 20 years.

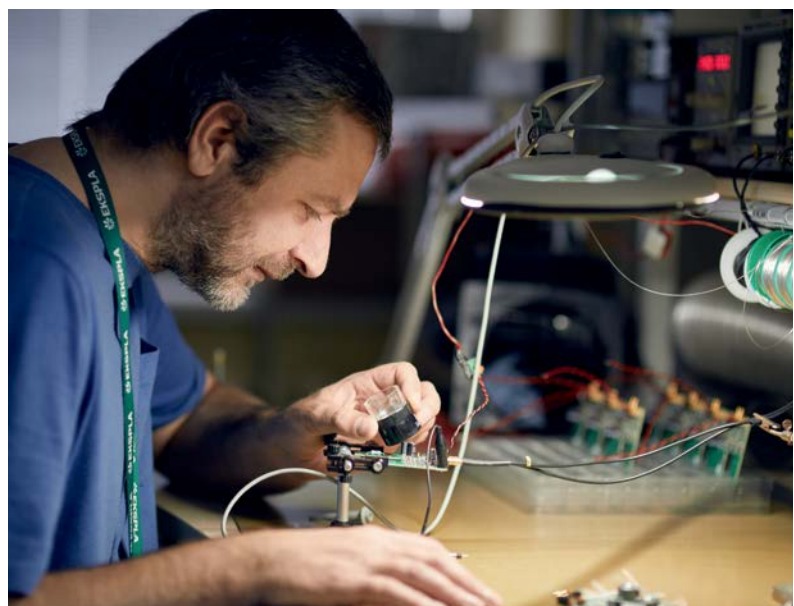

Contents

Laser Diode Drivers	3
uniLDD series Laser Diode Drivers	3
uniPS series Laser Power Supply & Control Unit	11
Pockels Cell Drivers	15
PCD & HV series Pockels Cell Drivers & HV Power Supplies	15
Digital Delay Generators	25
SY4000 Digital Delay Generator	25
Crystal Ovens and Thermocontrollers	29
KK1 & TK2 Crystal Oven and Thermocontroller	29
TK8 Nonlinear Crystal Oven with built-in Thermocontroller	31

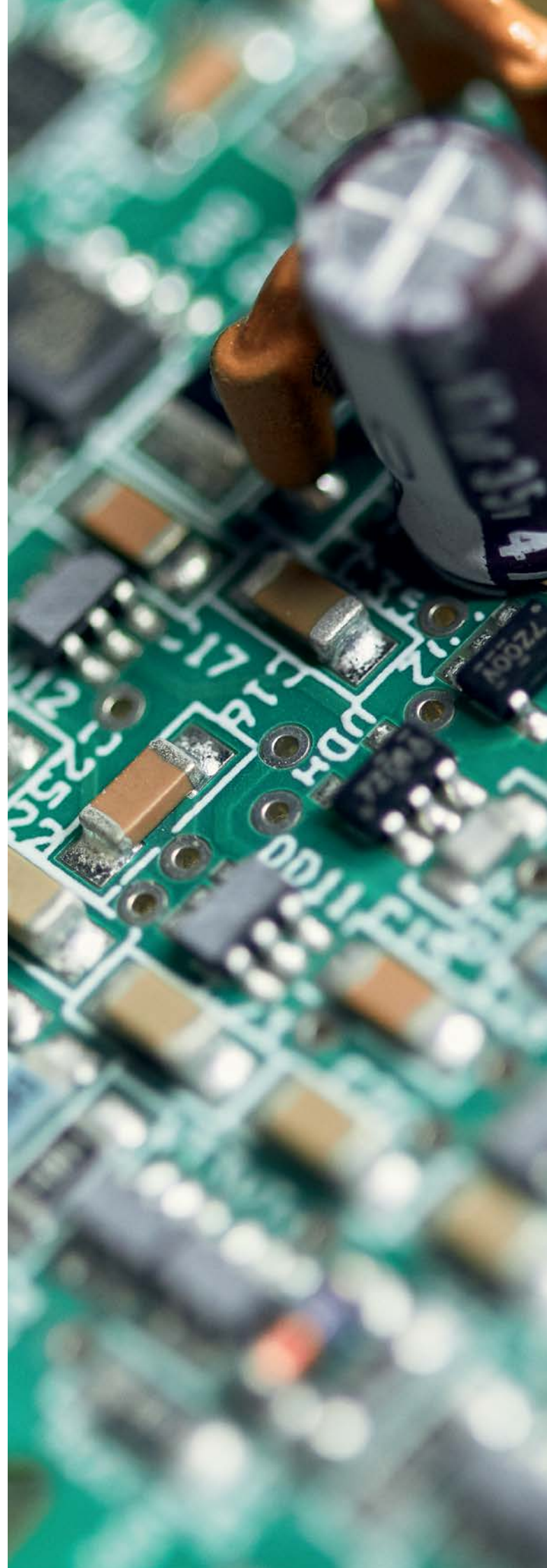

Laser Diode Drivers

uniLDD SERIES



Tri-uniLDD-A-QCW

uniLDD is the product line of laser diode drivers, also known as laser diode controllers, used in diode-pumped solid state lasers (DPSSL). The main purpose of laser diode drivers is to ensure precise current and temperature control of laser diodes.

Our laser diode drivers are compatible with a wide range of diodes (single emitters, bars, stacks, VCSELs, LEDs) and support both pulsed (QCW) and continuous (CW) operation modes.

Ekspla's laser diode controllers can provide currents from 10 A to 1200 A while maintaining < 0.1% pk-pk current ripple and amplitude stability. Compliance voltages of our laser diode drivers vary from 1 V to 600 V.

In the vast majority of cases we either partially customize or fully tailor our laser diode drivers for an optimal performance at customer's required regimes. For high-volume OEM customers we also tailor our laser diode controllers by removing excessive components to make sure drivers are optimal parameter, cost and size wise.

Certain uniLDD laser diode driver versions can simultaneously function as current sources for laser diodes and TEC controllers, also known as Peltier element thermocontrollers. Noted laser diode driver versions can contain up to two output channels, which can be utilized as two independent TEC controllers.

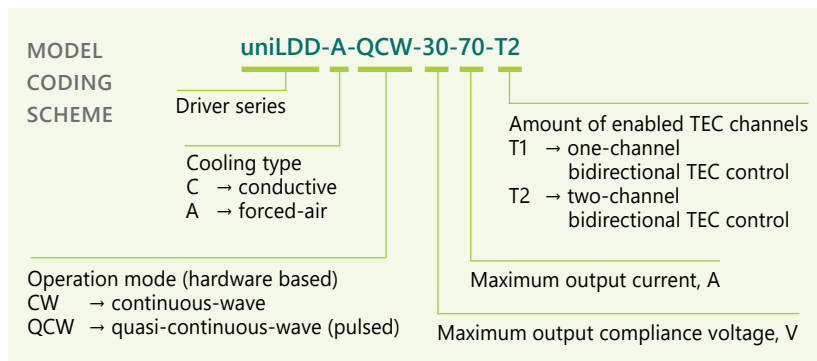



FEATURES



- ▶ Current range **from 10 A to 1200 A**
- ▶ Compliance voltage range **from 1 V to 600 V**
- ▶ Current stability of < **0.1% pk to pk**
- ▶ Current ripple of < **0.1% pk to pk**
- ▶ Output power up to **6 kW**
- ▶ Protections:
 - current transient (overload) protection;
 - open circuit shut-down;
 - over temperature shut-down;
 - power voltage brownout (voltage dip) shut-down;
 - interlock shut-down
- ▶ Drivers can function simultaneously as TEC controllers and LDD current sources
- ▶ Can be controlled via analog and digital (CAN, RS232) interfaces.
- ▶ Uniquely customizable modular design ensures drivers can be tailored to precisely meet OEM customer's needs
- ▶ Fast turnaround times between inquiry, prototyping and high-volume manufacturing stages

APPLICATIONS

EKSPLA laser diode drivers are optimal for pumping of femtosecond, picosecond, nanosecond and CW solid state lasers based on crystal, fiber or direct-diode technology. Most popular fields of applications are:

- ▶ Industrial lasers
micromachining, welding and cutting
- ▶ Medical lasers
ophthalmology, dermatology and surgery
- ▶ Scientific lasers
fusion research, spectroscopy, and high-energy physics

Model	uniLDD-C-CW		uniLDD-C-QCW		uniLDD-A-CW	
						
OUTPUT SPECIFICATIONS ¹⁾						
Operation mode	CW ²⁾	QCW ³⁾	CW	QCW ³⁾	CW	QCW
Compliance voltage range, min-max ⁴⁾	1 – 90 V ⁵⁾	-	1 – 90 V	1 – 85 V	1 – 85 V	-
Current range, min-max	10 – 100 A ⁶⁾		10 – 100 A	10 – 160 A	10 – 100 A	
Average power, max	3 kW ⁷⁾		3 kW	3 kW	2 kW	
Power conversion efficiency	90 – 98 %					
Current pulse amplitude stability	< 0.1 % pk to pk ⁸⁾					
Current ripple	< 0.1 % pk to pk ⁹⁾					
Current drift	< 0.2 % ¹⁰⁾					
Duty cycle	-		≤ 20 %		-	
Repetition rate, max			≤ 5 kHz			
Current rise time, typical			5 – 100 μs ¹¹⁾			
Current pulse duration, typical			up to 100 ms ¹²⁾			
RMS current, max			100 A			
Amount of functioning internal TEC control channels	0, 1 or 2 ¹³⁾					
TEC control current, min-max per channel	1 – 25 A					
TEC control voltage, min-max per channel	1 – 36 V					
TEC control power, max per channel	350 W					
INPUT SPECIFICATIONS						
DC power supply requirements (power stage), min	$U_{PS\ in\ min}\ (V) = U_{LDD\ out\ max} + 5$ $P_{PS\ in\ min}\ (W) = I_{LDD\ out\ max} * U_{LDD\ out\ max} * duty\ cycle_{max} / 100\ % * 1.2$					
DC power supply requirements (control stage)	12 V, 10 W				12 V, 15 W	
Control interfaces	analog, CAN & RS232 by default. USB, LAN & WLAN upon request ¹⁴⁾					
Software	Ekspla's control software & protocol description included by default					
Protections	current transient (overload) protection; open circuit shut-down; over temperature shut-down; power voltage brownout (voltage dip) shut-down; interlock shut-down					
PHYSICAL CHARACTERISTICS						
Dimensions (L x W x H) ¹⁵⁾	130 x 90 x 30 mm		130 x 90 x 54 mm		208 x 65 x 103 mm	
OPERATING REQUIREMENTS						
Cooling method	Conductive				Forced-air	
Operating ambient temperature	≤ 40 °C					
Operating baseplate temperature	≤ 50 °C				-	
ACCESSORIES						
CAN-USB adapter	Ekspla's CAN-USB adapter is required at evaluation stage if communication via CAN interface is needed					
Communication board	Ekspla's communication board which allows to control driver via RS232, USB, LAN, WLAN interfaces. Can be provided upon request					
Voltage booster board	Ekspla's booster board which allows to extend output compliance voltage of certain uniLDD versions. In certain cases output compliance voltage can be increased up to 600 V. Can be added at factory upon Ekspla's recommendations					
Baseplate	copper, included by default				aluminum, included upon request	
Output power cables	included upon request, custom dia and length					
Input power cables	included upon request, custom dia and length					
Control cables	included by default					
External capacitors	included upon Ekspla's recommendation. Custom mounting solutions for external capacitor are available upon request					

Model	uniLDD-A-QCW		Bi-uniLDD-A-QCW		Tri-uniLDD-A-QCW	
						
OUTPUT SPECIFICATIONS ¹⁾						
Operation mode	CW ²⁾	QCW	CW	QCW	CW	QCW
Compliance voltage range, min-max ⁴⁾	1 – 90 V ⁵⁾	1 – 85 V	1 – 90 V	1 – 85 V	1 – 90 V	1 – 85 V
Current range, min-max	10 – 100 A ⁶⁾	10 – 360 A	20 – 200 A	20 – 800 A	30 – 300 A	30 – 1200 A
Average power, max	2 kW ⁷⁾	2 kW	4 kW	4 kW	6 kW	6 kW
Power conversion efficiency	90 – 98 %					
Current pulse amplitude stability	< 0.1 % pk to pk ⁸⁾					
Current ripple	< 0.1 % pk to pk ⁹⁾					
Current drift	< 0.2 % ¹⁰⁾					
Duty cycle		≤ 20 %		≤ 20 %		≤ 20 %
Repetition rate, max		≤ 5 kHz		≤ 5 kHz		≤ 5 kHz
Current rise time, typical	–	5 – 100 μs	–	5 – 100 μs	–	5 – 100 μs
Current pulse duration, typical		up to 100 ms		up to 100 ms		up to 100 ms
RMS current, max		80 A		160 A		240 A
Amount of functioning internal TEC control channels	0, 1 or 2 ¹³⁾		0			
TEC control current, min-max per channel	1 – 25 A		–			
TEC control voltage, min-max per channel	1 – 36 V		–			
TEC control power, max per channel	350 W		–			
INPUT SPECIFICATIONS						
DC power supply requirements (power stage), min	$U_{PS\ in\ min}\ (V) = U_{LDD\ out\ max} + 5$ $P_{PS\ in\ min}\ (W) = I_{LDD\ out\ max} * U_{LDD\ out\ max} * duty\ cycle_{max} / 100\ % * 1.2$					
DC power supply requirements (control stage)	12 V, 15 W		12 V, 20 W		12 V, 25 W	
Control interfaces	analog, CAN & RS232 by default. USB, LAN & WLAN upon request ¹⁴⁾					
Software	Ekspla's control software & protocol description included by default					
Protections	current transient (overload) protection; open circuit shut-down; over temperature shut-down; power voltage brownout (voltage dip) shut-down; interlock shut-down					
PHYSICAL CHARACTERISTICS						
Dimensions (L x W x H) ¹⁵⁾	208 x 65 x 103 mm		250 x 146 x 98 mm		250 x 200 x 98 mm	
OPERATING REQUIREMENTS						
Cooling method	Forced-air					
Operating ambient temperature	≤ 40 °C					
ACCESSORIES						
CAN-USB adapter	Ekspla's CAN-USB adapter is required at evaluation stage if communication via CAN interface is needed					
Communication board	Ekspla's communication board which allows to control driver via RS232, USB, LAN, WLAN interfaces. Can be provided upon request					
Voltage booster board	Ekspla's booster board which allows to extend output compliance voltage of certain uniLDD versions. In certain cases output compliance voltage can be increased up to 600 V. Can be added at factory upon Ekspla's recommendations					
Baseplate	aluminum, included upon request		aluminum, included by default			
Output power cables	included upon request, custom dia and length					
Input power cables	included upon request, custom dia and length					
Control cables	included by default					
External capacitors	included upon Ekspla's recommendation. Custom mounting solutions for external capacitor are available upon request					

- 1) Due to continuous improvement, all specifications are subject to change without notice. Parameters marked typical are not specifications. They are indications of typical performance and will vary with each unit we manufacture.
- 2) Continuous-wave.
- 3) Quasi-continuous-wave (also known as pulsed).
- 4) Range between minimum and maximum limits. Not all maximal limits can be reached simultaneously.
- 5) Maximum compliance voltage can be extended for certain versions by using booster board layout. More – in section "Accessories" → "Booster board".
- 6) Maximum current can be extended for certain versions by connecting drivers in parallel.
- 7) Maximum power can be extended for certain versions by using booster board layout. More information in section "Accessories" → "Booster board".
- 8) In $\times 0.5... \times 1$ of max current range.
- 9) DC...100 kHz bandwidth, in $\times 0.5... \times 1$ of max current range.
- 10) Cold start, 8 h period, after 5 min. warm up.
- 11) Factory software tuned upon customer's request.
- 12) Factory software & hardware tuned upon customer's request.
- 13) Amount factory enabled upon customer's request.
- 14) USB, LAN & WLAN control interfaces are available upon customer's request while using Ekspla's external communication board.
- 15) External driver dimensions can vary ± 20 mm due to the minor hardware variations like fans and current sensors.

TYPICAL PERFORMANCE EXAMPLE OF uniLDD-A-CW

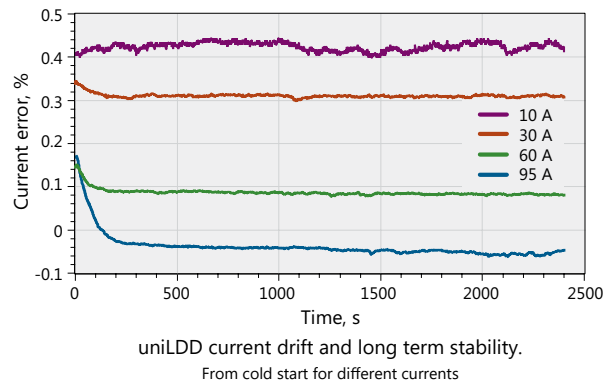
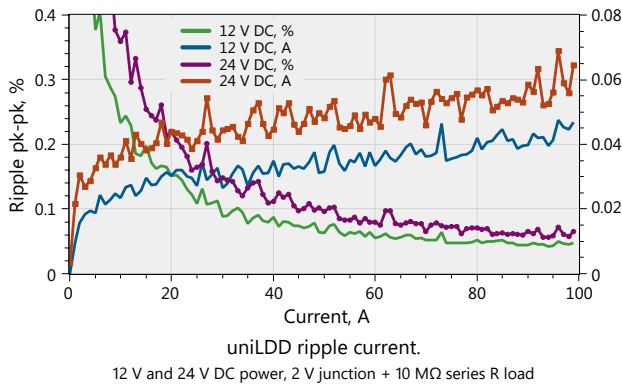

PEAK PERFORMANCE EXAMPLE OF CUSTOM Tri-uniLDD-A-QCW

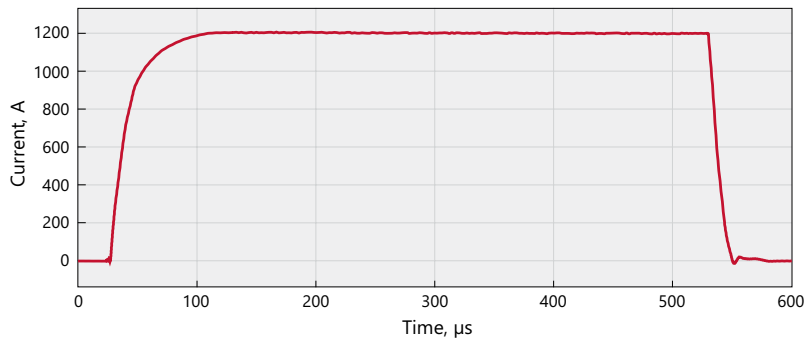

I_{out} 1195 A, U_{out} 473 V, PW 500 us, f 10 Hz, rise 36 μs, fall 14 μs, overshoot 0.7%

ANALOG INTERFACE PINOUT

Pin	Signal name	Direction	Voltage level	Description
1	Enable	Input	TTL (LVTTTL) 200 μ A pull up to 3.3 V	The Enable function gives permission to operate for TEC driver and consequently for LDD driver.
2	Ready To Operate (RTO)	Input/Output through 330 Ω resistor	> 2.4 V driver output is active, < 0.5 V output is clamped	RTO is tied to 'High' by the driver when 'Active RTO ' is enabled and the driver is in active state. Alarms clamp RTO low and disable driver output. External device may clamp RTO to GND and disable driver output. RTO allows to join fault circuits of several drivers connected in parallel
3	Interlock	Input	10 k Ω pull up to 3.3 V, LOW = < 0.4 V	The Interlock function can be connected to external safety or machine protection switches such as door or temperature switches. Open = OFF Connect to GND = RUN
4	GND			
5	V _{out} Monitor	Output	V _{out} , driver output voltage	The output voltage monitor. V _{out} = Diode compliance voltage + voltage drop on connection wires
6	I _{out} Monitor	Output	0 - 10 V* = 0 - I _{outmax}	The output current monitor
7	I _{program}	Input	0 - 10 V* = 0 - I _{outmax}	Output current setting or modulating by applying a voltage, CW and Pulse mode
8	Pulse Control	Input	TTL, LVTTTL positive pulse	In TriggerIN mode: trigger input. A rising pulse provided to this connector will trigger an output current pulse of a preset width. In Time-gated mode: input to start/stop the output current." Connection "Trigger input" performs the same function
9	GND			
10	+5V	Output	Auxiliary 200 mA	
11	+5V	Output	Auxiliary 200 mA	
12	-15V	Output	Auxiliary 100 mA	
13	+15V	Output	Auxiliary 200 mA	
14	+15V	Output	Auxiliary 200 mA	
15	GND			

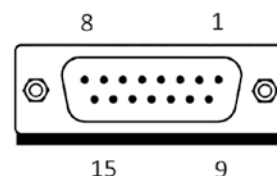

D-sub 15-pin female analog interface connector.

Laser diode drivers

Pockels cell drivers

Pulse and delay generators

Crystal ovens and thermocontrollers

DRAWINGS & IMAGES

Laser diode drivers

Pockeils cell drivers

Pulse and delay generators

Crystal ovens and thermocontrollers

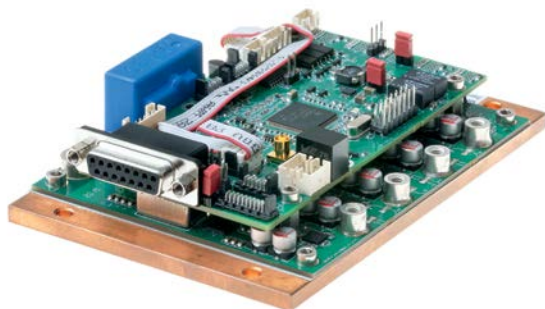

uniLDD-C-CW

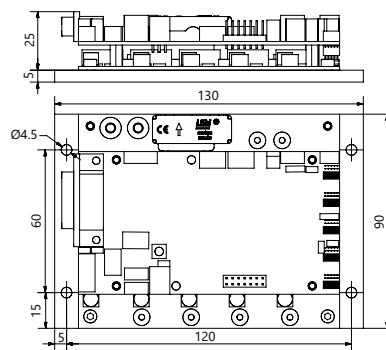

uniLDD-C-QCW

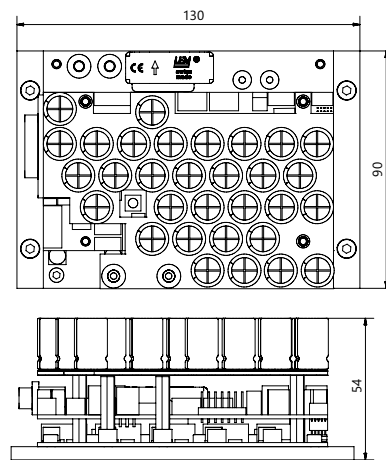

uniLDD-A-CW

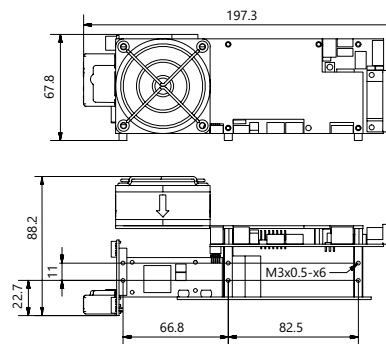

uniLDD-A-QCW

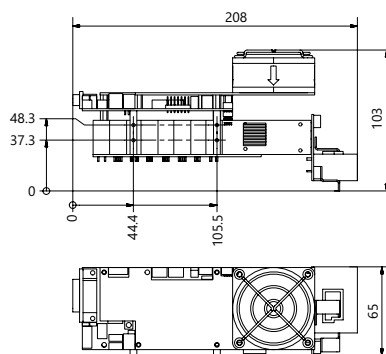

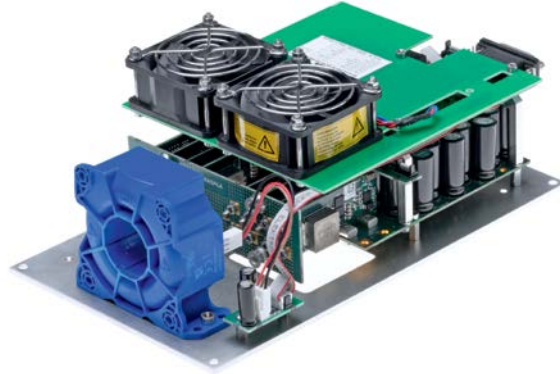

Bi-uniLDD-A-QCW

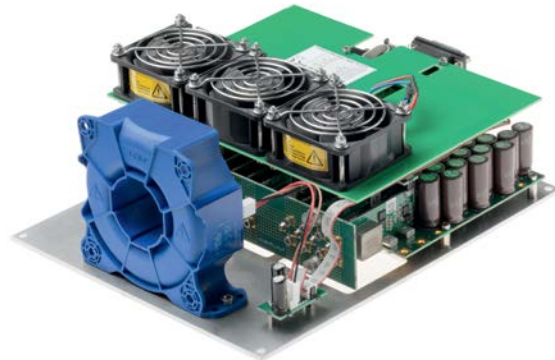
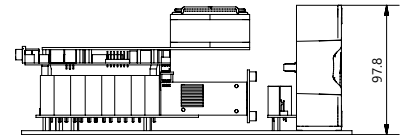
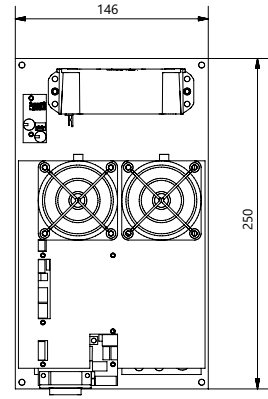

Tri-uniLDD-A-QCW

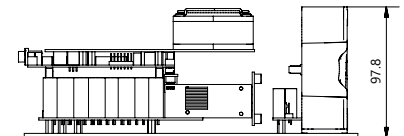
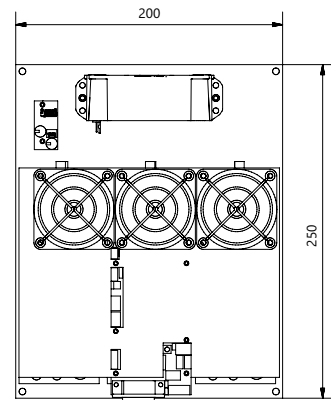

Example of a typical uniPS system



COMPUTER / TABLET

Control Software
(Default or Customer-Tailored)

POWER SUPPLY & CONTROL UNIT

Laser's Main Control /
Communication Board

Digital Delay
Generator

Laser Diode Driver

AC/DC Power Supply

Capacitor Board

TEC Controller(s)

LASER HEAD

Laser Diode



Laser Power Supply & Control Unit

uniPS SERIES



Front panel view

The uniPS series is a 19" rack-mount power supply with optional control-unit configurations, which serves as a platform that integrates and extends the capabilities of Ekspla's open-frame uniLDD laser diode drivers. The uniPS power supply combines uniLDD laser diode drivers with a wide range of complementary electronic modules, including AC-DC power supplies, the laser's main control/communication board, a digital delay generator, TEC controllers, and other Ekspla-designed hardware.

When equipped with the control-unit options, the uniPS includes features such as an integrated laser main control/communication board (Lazserv OEM) and an eight-channel digital delay generator (SY4000 OEM), both operated via the Ekspla

Control software. This software manages all control, monitoring, and communication with the laser system modules, eliminating the need for customers to develop their own PC software. LabVIEW drivers are available upon request, enabling straightforward integration into laboratory automation and data-acquisition environments. The user interface and functionality can also be customized by Ekspla to meet specific customer requirements.

The uniPS platform is modular, allowing hardware modules to be added or removed and software to be expanded or upgraded as needed, providing flexibility to meet individual system power and operational requirements.

FEATURES

- ▶ **Current range from 10 A to 1200 A**
- ▶ **Compliance voltage range from 1 V to 600 V**
- ▶ **Current stability of < 0.1% pk to pk**
- ▶ **Current ripple of < 0.1% pk to pk**
- ▶ **Average output power up to 6 kW**
- ▶ **Protections:**
 - current transient (overload) protection;
 - open circuit shut-down;
 - over temperature shut-down;
 - power voltage brownout (voltage dip) shut-down;
 - interlock shut-down
- ▶ **Can be controlled via analog and digital (CAN, RS232) interfaces**
- ▶ **Optional integrated AC-DC power supplies, laser's main control/communication board, digital delay generators, TEC controllers, and other Ekspla-designed hardware**
- ▶ **Control unit options (integrated control/communication board +8 independent output channel digital delay generator board, tailor-made laser system control software). LabVIEW drivers available upon request**
- ▶ **Customer-tailored front and back panel connector layout as well as unit's outer dimensions**

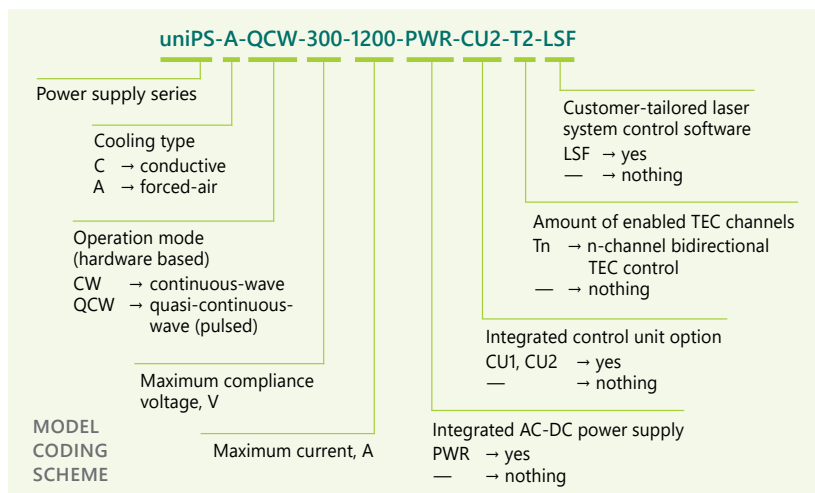

APPLICATIONS

Optimal for powering and controlling diode-pumped solid-state laser systems employed in industrial, medical, scientific, and defense fields. The most common applications include:

- ▶ Inertial confinement fusion
- ▶ Laser diode burn-in systems
- ▶ Parallel laser processing
- ▶ Directed energy

SPECIFICATIONS ¹⁾

Model	uniPS	
OUTPUT SPECIFICATIONS		
Operation mode	CW ²⁾	QCW ³⁾
Compliance voltage range, min-max ⁴⁾	1 – 120 V	1 – 600 V
Current range, min-max	10 – 300 A	10 – 1200 A
Average power, max	6 kW	6 kW
Power conversion efficiency	90 – 98 %	
Current pulse amplitude stability	< 0.1 % pk to pk ⁵⁾	
Current ripple	< 0.1 % pk to pk ⁶⁾	
Current drift	< 0.2 % ⁷⁾	
Duty cycle		≤ 20 %
Repetition rate, max		≤ 5 kHz
Current rise time, typical	–	5 – 100 μs ⁸⁾
Current pulse duration, typical		up to 100 ms ⁹⁾
RMS current, max		300 A
Amount of functioning internal TEC control channels	as many as needed ¹⁰⁾	
TEC control current, min-max per channel	1 – 25 A standard, more – upon request	
TEC control voltage, min-max per channel	1 – 36 V, standard, more – upon request	
TEC control power, max per channel	350 W, standard, more – upon request	
INPUT SPECIFICATIONS		
DC power supply requirements (power stage), min typical	$U_{PS\ in\ min}\ (V) = U_{uniPS\ out\ max} + 5$ $P_{PS\ in\ min}\ (W) = I_{uniPS\ out\ max} * U_{uniPS\ out\ max} * duty\ cycle_{max} / 100\ % * 1.2$	
AC mains requirements (power stage), typical	200 – 240 VAC, single phase, 50/60 Hz standard, other - upon request	
Control interfaces	analog, CAN & RS232 by default. USB, LAN & WLAN upon request	
Software	Ekspla's standard control software & protocol description included by default	
Protections	current transient (overload) protection; open circuit shut-down; over temperature shut-down; power voltage brownout (voltage dip) shut-down; interlock shut-down	
PHYSICAL CHARACTERISTICS		
Dimensions (W x H x D)	19" x U3 x 435 mm standard, other size - upon request	
OPERATING REQUIREMENTS		
Cooling method	forced-air standard, conductive/water – upon request	
Operating ambient temperature	≤ 40 °C	
OPTIONS		
PWR	integrated AC-DC power supply option	
CU1	control unit, first option. Integrated Ekspla's laser control/communication board Lazserv OEM for additional USB, LAN, WLAN communication options, standard software	
CU2	control unit, second option. CU1 + integrated 8 independent output channel Ekspla's digital delay generator board SY4000 OEM. More information – page 25	
T#	number of independent TEC control channels	
LSF	customer-tailored laser system control software (default Ekspla Control software altered functionality & UI design wise)	
ACCESSORIES		
Output power cables	included upon request, custom dia and length	
Input power cables	included upon request, custom dia and length	
Control cables	included by default, custom length	
CAN-USB adapter	included upon request	

¹⁾ Due to continuous improvement, all specifications are subject to change without notice. Parameters marked typical are not specifications. They are indications of typical performance and will vary with each unit we manufacture.

²⁾ Continuous-wave.

³⁾ Quasi-continuous-wave (also known as pulsed).

⁴⁾ Range between minimum and maximum limits. Not all maximal limits can be reached simultaneously.

⁵⁾ In $\times 0.5... \times 1$ of max current range.

⁶⁾ DC...100 kHz bandwidth, in $\times 0.5... \times 1$ of max current range.

⁷⁾ Cold start, 8 h period, after 5 min. warm up.

⁸⁾ Factory software tuned upon customer's request.

⁹⁾ Factory software & hardware tuned upon customer's request.

¹⁰⁾ Amount factory enabled upon customer's request.

TYPICAL PERFORMANCE EXAMPLE OF uniLDD-A-CW INTEGRATED INSIDE OF A uniPS POWER SUPPLY

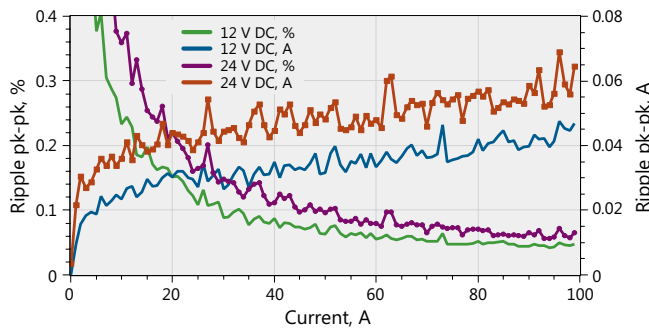

uniLDD ripple current.
12 V and 24 V DC power, 2 V junction + 10 MΩ series R load

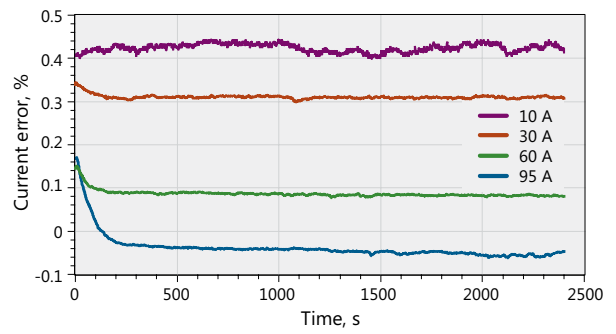

uniLDD current drift and long term stability.
From cold start for different currents

PEAK PERFORMANCE EXAMPLE OF uniPS POWER SUPPLY

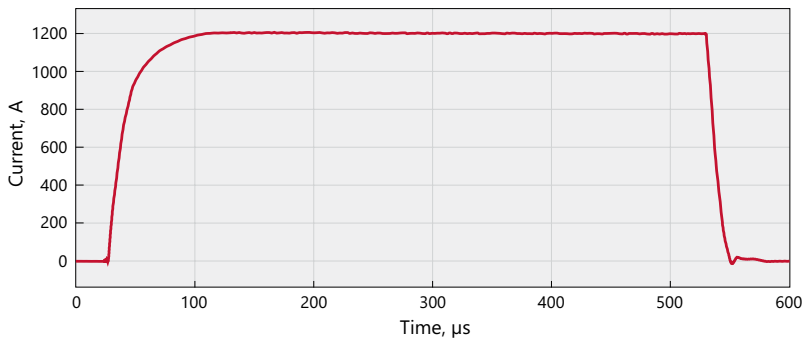

I_{out} 1195 A, U_{out} 473 V, PW 500 μs, f 10 Hz, rise 36 μs, fall 14 μs, overshoot 0.7%

Laser diode drivers

Pockels cell drivers

Pulse and delay generators

Crystal ovens and thermocontrollers

DRAWINGS & IMAGES



Front panel view.



Back panel view.
Default (no control unit options applied)



Example of uniPS power supply with all integrated control unit options (CU2)

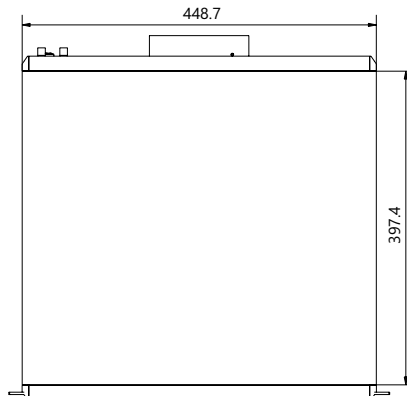
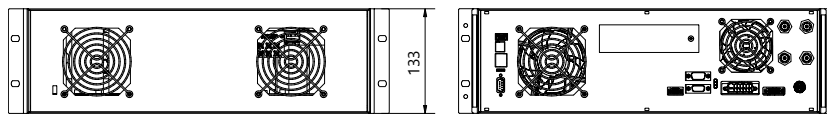

Laser diode drivers

Pockels cell drivers

Pulse and delay generators

Crystal ovens and thermocontrollers

Pockels Cell Drivers & HV Power Supplies

PCD & HV SERIES



PCD-UHR-I-250-5.2-C

Pockels cell drivers, also known as fast HV switches, are designed to load and unload capacitance of Pockels cells which serve as an integral part of electro optic modulators (EOM's) used for pulse picking, mode-locking, cavity dumping and q-switching of solid state lasers. Ekspla's Pockels cell drivers are optimal for BBO, RTP, KD*P, KTP, LiNbO₃, CdTe Pockels cells.

Our Pockels cell drivers can provide high voltage output pulses up to 9.8 kV, repetition rates up to 6 MHz, electrical pulse rise times as short as 5.5 ns, minimal pulse durations as low as 0 ns and maximal pulse durations

with no limit. All specifications are measured at 6 pF load.

Ekspla's Pockels cell drivers require HV supply input typically equal to driver's HV output (the only exception is PCD-FAM series drivers that allow to modulate the amplitude of each individual driver's output pulse by analog voltage input). We provide complimentary HV power supplies for each Pockels cell driver version. For high-volume OEM customers we also tailor our Pockels cell drivers by removing excessive components to make sure products are optimal parameter, cost and size wise.

FEATURES

- ▶ HV repetition rates up to **6 MHz**
- ▶ HV output pulse amplitude up to **9.8 kV**
- ▶ Electrical HV rise / fall times typically as low as **5.5 ns** at 6pF load
- ▶ HV pulse durations **from 0 ns to infinity**
- ▶ Amplitude modulation of independent HV output pulses
- ▶ Designed for **BBO, RTP, KD*P, KTP, LiNbO₃, CdTe** Pockels cells
- ▶ Complimentary HV power supplies for each driver version
- ▶ Drivers can be tailored to precisely meet OEM customer's needs
- ▶ Fast turnaround times between inquiry, prototyping and high-volume manufacturing stages.

APPLICATIONS

EKSPLA's Pockels cell drivers are optimal for pulse picking, mode-locking, cavity dumping and q-switching of the solid state femtosecond, picosecond and nanosecond lasers. Most popular fields of applications are:

- ▶ Industrial lasers
micromachining, welding and cutting
- ▶ Medical lasers
ophthalmology, dermatology and surgery
- ▶ Scientific lasers
fusion research, spectroscopy, and high-energy physics

PERFORMANCE

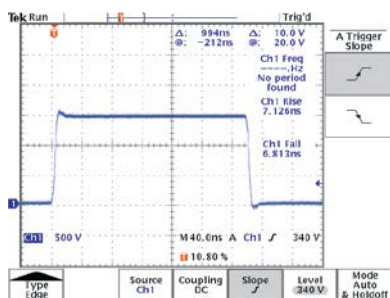

Typical output pulse shape

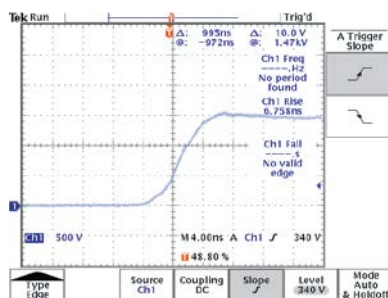

Typical rising front of output pulse in detail

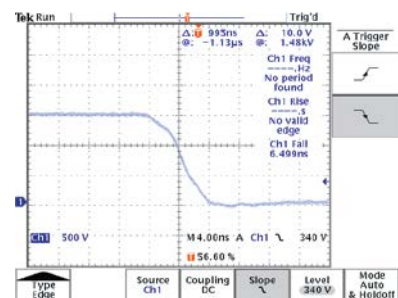

Typical falling front of output pulse in detail

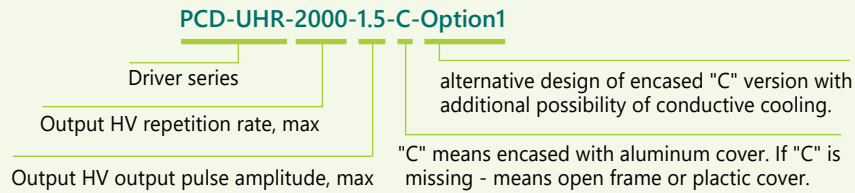
MODEL CODING
SCHEMEGENERAL SPECIFICATIONS ¹⁾

Model	PCD-UHR series	2PCD-UHR series	PCD-UHRS series	PCD-UHV series	PCD-FAM series
OUTPUT SPECIFICATIONS					
HV ¹⁾ pulse amplitude, max ²⁾	7.2 kV	3.4 kV	3.6 kV	9.8 kV	2.5 kV
HV repetition rate (without burst), max	3 MHz	6 MHz	1 MHz	10 kHz	500 kHz
HV repetition rate (in burst mode), max	4.8 MHz	–	4.8 MHz	–	
HV pulse rise / fall times, min ³⁾ at 6 pF load	< 5.5 ns	< 6 ns	< 5.5 ns	< 6 ns	< 26 / 13 ns
HV pulse duration, min	100 ns	0 ns	25 ns	30 ns	70 ns
HV pulse duration extension to infinity using pulse regeneration technique	YES	NO			
Modulation of an individual HV pulse amplitude	NO				YES
Minimum pause between HV pulses	100 ns		25 ns	100 ns	
HV pulse delay	25 – 30 ns, depends on model ⁴⁾	30 – 45 ns, depends on model	30 ns	30 ns	45 ns
HV pulse jitter	< 100 ps				
INPUT SPECIFICATIONS					
Power supply requirements (power stage)	$U_{HV\ PS\ in} (V) = U_{driver\ out}$				$U_{HV\ PS\ in} (V) = 2.65 - 2.7\ kV$
	$P_{PS\ in} (W)$ according to section "Model selection table"				
Power supply requirements (control stage)	24 V				
Amount of External triggering input pulses	1 or 2				
Triggering pulse duration requirement (for two-pulses triggering mode only)	> 20 ns				
Triggering pulse amplitude requirement	3.5 – 5 V (50 Ω input)				
Triggering pulse rise & fall time requirement	< 10 ns	< 5 ns	< 10 ns		
Modulation voltage range	–				0.1 – 4.9 V
PHYSICAL CHARACTERISTICS					
Dimensions	according to section "Drawings"				
OPERATING REQUIREMENTS					
Capacitance of load (Pockels cell)	typically ≤ 6 pF. If higher, please consult with Ekspla				
Length of leads to load (Pockels cell), max	10 cm				
Cooling method	conductive, water or no cooling. According to section "Model selection table"				
Operating ambient temperature	≤ 35°C				
Operating baseplate temperature	≤ 35°C				
ACCESSORIES					
HV output pins	2 pc. of pins for HV wires included by default. HV wires between driver and a Pockels cell not included				
HV input cables	included by default				
Control cables	included by default				
HV power supply	complimentary HV power supplies available according to section "HV power supplies"				
CAN-USB adapter (for HV power supply)	Ekspla's CAN-USB adapter is required at evaluation stage if communication via CAN interface is needed				

¹⁾ Due to continuous improvement, all specifications are subject to change without notice. Parameters marked typical are not specifications. They are indications of typical performance and will vary with each unit we manufacture.

²⁾ High voltage.

³⁾ Maximal limit. Not all maximal limits can be reached simultaneously.

⁴⁾ Minimal limit.

MODEL SELECTION TABLE ¹⁾

Model	HV repetition rate, max ²⁾	HV output pulse amplitude, max	Electrical HV pulse rise / fall times, typical ³⁾	HV pulse duration range, min–max ⁴⁾	HV power consumption, max ³⁾	Cooling method	Dimensions (L×W×H)
PCD-UHR SERIES							
PCD-UHR-50-3.6	50 kHz	3.6 kV	< 7 ns	100–5000 ns	20 W	Conductive	94×63×31 mm
PCD-UHR-50-3.6-C						Water	114×73×50 mm
PCD-UHR-50-3.6-C-Option1						Conductive or water	116×68×42 mm
PCD-UHR-250-2.6	250 kHz	2.6 kV	< 6 ns	100–3900 ns	40 W	Conductive or water	116×63×38 mm
PCD-UHR-250-2.6-C						Water	114×73×50 mm
PCD-UHR-250-2.6-C-Option1						Conductive or water	116×68×42 mm
PCD-UHR-250-3.6	250 kHz	3.6 kV	< 7 ns	100–3900 ns	75 W	Conductive or water	116×63×38 mm
PCD-UHR-250-3.6-C						Water	114×73×50 mm
PCD-UHR-250-3.6-C-Option1						Conductive or water	116×68×42 mm
PCD-UHR-400-1.5	400 kHz	1.5 kV	< 5.5 ns	100–2400 ns	20 W	Conductive or water	116×63×38 mm
PCD-UHR-400-1.5-C						Water	114×73×50 mm
PCD-UHR-400-1.5-C-Option1						Conductive or water	116×68×42 mm
PCD-UHR-500-2.6	500 kHz	2.6 kV	< 6.5 ns	100–1900 ns	90 W	Conductive or water	116×63×38 mm
PCD-UHR-500-2.6-C						Water	114×73×50 mm
PCD-UHR-500-2.6-C-Option1						Conductive or water	116×68×42 mm
PCD-UHR-1000-1.8	1 MHz	1.8 kV	< 6 ns	100–900 ns	80 W	Conductive or water	116×63×38 mm
PCD-UHR-1000-1.8-C						Water	114×73×50 mm
PCD-UHR-1000-1.8-C-Option1						Conductive or water	116×68×42 mm
PCD-UHR-2000-1.5	2 MHz	1.5 kV	< 7 ns	100–400 ns	120 W	Conductive or water	116×63×38 mm
PCD-UHR-2000-1.5-C						Water	114×73×50 mm
PCD-UHR-2000-1.5-C-Option1						Conductive or water	116×68×42 mm
PCD-UHR-I-250-5.2-C	250 kHz	5.2 kV	< 8.5 ns	100–5000 ns	100 W	Conductive or water	158×49×81 mm
PCD-UHR-I-300-4.6-C	300 kHz	4.6 kV	< 8 ns	100–5000 ns	100 W	Conductive or water	158×49×81 mm
PCD-UHR-I-350-4-C	350 kHz	4 kV	< 7.5 ns	100–5000 ns	100 W	Conductive or water	158×49×81 mm
PCD-UHR-I-1000-3.0-C	1 MHz	3 kV	< 7.5 ns	100–5000 ns	120 W	Conductive or water	158×49×81 mm
PCD-UHR-II-150-7.0	150 kHz	7 kV	< 9.5 ns	100–5000 ns	110 W	Conductive	148×74×33 mm
PCD-UHR-II-250-7.0-C	250 kHz	7 kV	< 9.5 ns	100–5000 ns	200 W	Conductive or water	172×77×51 mm
PCD-UHR-II-1000-3.8-C	1 MHz	3.8 kV	< 6 ns	100–5000 ns	230 W	Conductive or water	172×77×51 mm
PCD-UHR-II-1000-4.0-C	1 MHz	4 kV	< 9.5 ns	100–5000 ns	210 W	Conductive or water	172×77×51 mm
PCD-UHR-III-500-7.2-C	500 kHz	7.2 kV	< 8 ns	100–1900 ns	400 W	Water	220×87×98 mm
PCD-UHR-III-2000-3.4-C	2 MHz	3.4 kV	< 8.5 ns	100–400 ns	360 W	Water	220×87×98 mm
PCD-UHR-III-2500-3.1-C	2.5 MHz	3.1 kV	< 9.5 ns	100–300 ns	360 W	Water	220×87×98 mm
PCD-UHR-III-3000-2.6-C	3 MHz	2.6 kV	< 8.5 ns	100–233 ns	325 W	Water	220×87×98 mm

¹⁾ Due to continuous improvement, all specifications are subject to change without notice.²⁾ Without burst.³⁾ At 6 pF load.⁴⁾ Without extension to infinity.

Model	HV repetition rate, max ²⁾	HV output pulse amplitude, max	Electrical HV pulse rise / fall times, typical ³⁾	HV pulse duration range, min–max ⁴⁾	HV power consumption, max ³⁾	Cooling method	Dimensions (L×W×H)
2PCD-UHR SERIES							
2PCD-UHR-500-3.4-C	500 kHz	3.4 kV	< 7 ns	0–1900 ns	150 W	Water	210×98×53 mm
2PCD-UHR-1000-2.4-C	1 MHz	2.4 kV	< 6.5 ns	0–900 ns	180 W	Water	210×98×53 mm
2PCD-UHR-2000-1.6-C	2 MHz	1.6 kV	< 6 ns	0–400 ns	130 W	Water	210×98×53 mm
2PCD-UHR-II-300-3.4	300 kHz	3.4 kV	< 7 ns	0–1556 ns	110 W	Conductive	148×74×33 mm
2PCD-UHR-II-500-3.4-C	500 kHz	3.4 kV	< 7 ns	0–900 ns	200 W	Conductive or water	172×77×51 mm
2PCD-UHR-II-1000-2.5-C	1 MHz	2.5 kV	< 7 ns	0–400 ns	170 W	Conductive or water	172×77×51 mm
2PCD-UHR-II-2000-1.8-C	2 MHz	1.8 kV	< 7 ns	0–150 ns	210 W	Conductive or water	172×77×51 mm
2PCD-UHR-II-2000-1.5-C	2 MHz	1.5 kV	< 6 ns	100–900 ns	215 W	Conductive or water	172×77×51 mm
2PCD-UHR-III-4000-1.7-C	4 Mhz	1.7 kV	< 10.5 ns	100–300 ns	360 W	Water	220×87×98 mm
2PCD-UHR-III-6000-1.3-C	6 MHz	1.3 kV	< 9 ns	100–233 ns	350 W	Water	220×87×98 mm
PCD-UHRS SERIES							
PCD-UHRS-50-3.6	50 kHz	3.6 kV	< 7 ns	25–5000 ns	20 W	Conductive	94×63×31 mm
PCD-UHRS-50-3.6-C						Water	114×73×50 mm
PCD-UHRS-50-3.6-C-Option1						Conductive or water	116×68×42 mm
PCD-UHRS-250-3.6	250 kHz	3.6 kV	< 7 ns	25–1000 ns	75 W	Conductive or water	116×63×38 mm
PCD-UHRS-250-3.6-C						Water	114×73×50 mm
PCD-UHRS-250-3.6-C-Option1						Conductive or water	116×68×42 mm
PCD-UHRS-250-2.6	250 kHz	2.6 kV	< 6 ns	25–1000 ns	40 W	Conductive or water	116×63×38 mm
PCD-UHRS-400-1.5	400 kHz	1.5 kV	< 5.5 ns	25–625 ns	20 W	Conductive or water	116×63×38 mm
PCD-UHRS-500-2.6	500 kHz	2.6 kV	< 6.5 ns	25–500 ns	90 W	Conductive or water	116×63×38 mm
PCD-UHRS-500-2.6-C						Water	114×73×50 mm
PCD-UHRS-500-2.6-C-Option1						Conductive or water	116×68×42 mm
PCD-UHRS-1000-1.8	1 MHz	1.8 kV	< 6 ns	25–250 ns	80 W	Conductive or water	116×63×38 mm
PCD-UHRS-1000-1.8-C						Water	114×73×50 mm
PCD-UHRS-1000-1.8-C-Option1						Conductive or water	116×68×42 mm
PCD-UHV SERIES							
PCD-UHV-4.2	10 kHz	4.2 kV	< 6 ns	30–3000 ns	5 W	Not needed	140×60×29 mm
PCD-UHV-4.2-C							192×81×75 mm
PCD-UHV-5.5	5 kHz	5.5 kV	< 7 ns	30–3000 ns	5 W	Not needed	140×60×29 mm
PCD-UHV-5.5-C							192×81×75 mm
PCD-UHV10-8.6	3 kHz	8.6 kV	< 10.5 ns / < 9.5 ns	35–2000 ns	5 W	Not needed	140×75×29 mm
PCD-UHV10-8.6-C							192×81×75 mm
PCD-UHV10-9.8	2.5 kHz	9.8 kV	< 12 ns / < 10.5 ns	35–2000 ns	5 W	Not needed	140×75×29 mm
PCD-UHV10-9.8-C							192×81×75 mm
PCD-FAM SERIES							
PCD-FAM-250-2.5-C	250 kHz	2.5 kV	< 26 ns / < 13 ns	70–3000 ns	60 W	Conductive or water	139×69×57 mm
PCD-FAM-500-2.5-C	500 kHz	2.5 kV	< 26 ns / < 13 ns	70–1000 ns	120 W	Conductive or water	139×69×57 mm

¹⁾ Due to continuous improvement, all specifications are subject to change without notice.

²⁾ Without burst.

³⁾ At 6 pF load.

⁴⁾ Without extension to infinity.

HV POWER SUPPLIES SPECIFICATIONS ¹⁾

Model	Output power, max	High voltage output options, max	Dimensions (L x W x H)	
ENCASED HV POWER SUPPLY				
HV-200	200 W	1.8, 2.6, 3.6, 4.0 kV	200 x 119 x 76 mm	Input voltage: 48 V Output voltage (main): $U_{out\ range} (kV) = 0 - U_{out\ max}$ Output voltage (auxiliary): 24 V Control options: CAN, RS232, trimmer or analog (optional)
HV-400	400 W			
HV-2x200	2 x 200 W	±1.5, ±2.0, ±2.6, ±3.6 kV		
HV-170	170 W	1.8, 2.6, 3.6 kV	52 x 80 x 58 mm	Input voltage: 24 V Output voltage range: $U_{out\ range} (kV) = 0.4 \times U_{out\ max} - U_{out\ max}$ Control options: CAN, trimmer or analog (optional)
HV-2x85	2 x 85 W	±1.5, ±1.8 kV		
OPEN FRAME (PCB) HV POWER SUPPLY				
HV05Wm	5 W	1.8, 2.8, 4.0, 4.4, 5.0 kV	135 x 45 x 27 mm	Input voltage: 24 V Output voltage range: $U_{out\ range} (kV) = 0.4 \times U_{out\ max} - U_{out\ max}$ Control options: CAN, trimmer or analog (optional)
HV05Wm-CAN ²⁾				
HV40Wm	40 W	1.3, 1.8, 2.5, 3.6, 4.0 kV	160 x 70 x 35 mm	
HV40Wm-CAN				
HV80Wm	80 W	1.8, 2.6, 3.1, 3.6, 4.0 kV	175 x 70 x 45 mm	
HV80Wm-CAN				
HV120Wm	120 W	1.8, 2.6, 3.1, 3.6 kV	175 x 110 x 42 mm	
HV120Wm-CAN				
HV2x60Wm	2 x 60 W	±1.4, ±2.0, ±2.6, ±3.6 kV	175 x 110 x 42 mm	
HV2x60Wm-CAN				

¹⁾ Due to continuous improvement, all specifications are subject to change without notice. Parameters marked typical are not specifications. They are indications of typical performance and will vary with each unit we manufacture.

²⁾ For CAN communication at evaluation stage Ekspla's CAN-USB adapter is required.

DRAWINGS & IMAGES OF POCKELS CELL DRIVERS

- PCD-UHR-50-3.6
- PCD-UHR-250-2.6
- PCD-UHR-250-3.6
- PCD-UHR-400-1.5
- PCD-UHR-500-2.6
- PCD-UHR-1000-1.8
- PCD-UHR-2000-1.5

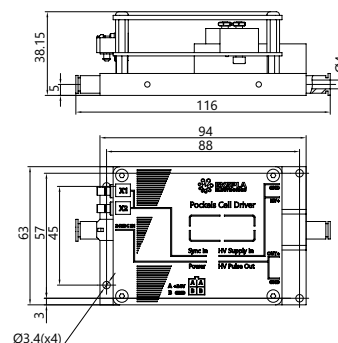

- PCD-UHR-50-3.6-C
- PCD-UHR-250-2.6-C
- PCD-UHR-250-3.6-C
- PCD-UHR-400-1.5-C
- PCD-UHR-500-2.6-C
- PCD-UHR-1000-1.8-C
- PCD-UHR-2000-1.5-C

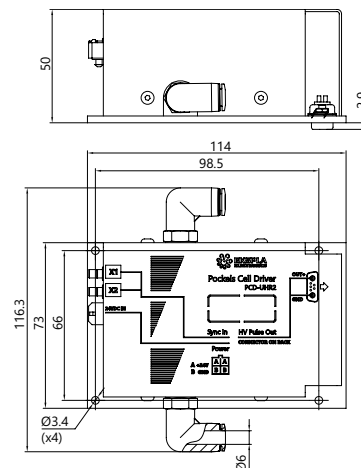

Laser diode drivers

Pockels cell drivers

Pulse and delay generators

Crystal ovens and thermocontrollers

- PCD-UHR-50-3.6-C-Option1
- PCD-UHR-250-2.6-C-Option1
- PCD-UHR-250-3.6-C-Option1
- PCD-UHR-400-1.5-C-Option1
- PCD-UHR-500-2.6-C-Option1
- PCD-UHR-1000-1.8-C-Option1
- PCD-UHR-2000-1.5-C-Option1

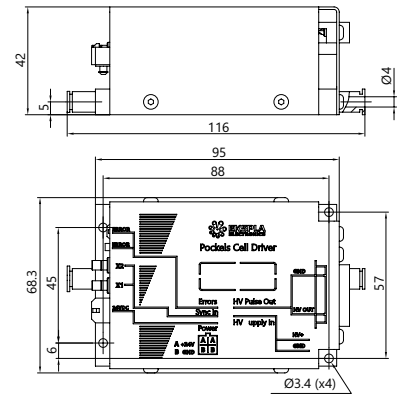

- PCD-UHR-I-250-5.2-C
- PCD-UHR-I-300-4.6-C
- PCD-UHR-I-350-4-C
- PCD-UHR-I-1000-3.0-C

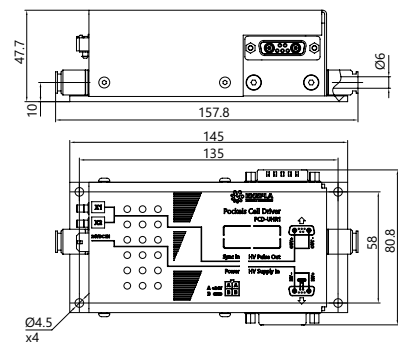

- PCD-UHR-II-150-7.0
- 2PCD-UHR-II-300-3.4

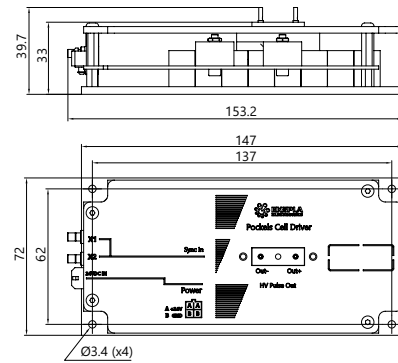

- PCD-UHR-II-250-7.0-C
- PCD-UHR-II-1000-3.8-C
- PCD-UHR-II-1000-4.0-C
- 2PCD-UHR-II-500-3.4-C
- 2PCD-UHR-II-1000-2.5-C
- 2PCD-UHR-II-2000-1.8-C
- 2PCD-UHR-II-2000-1.5-C

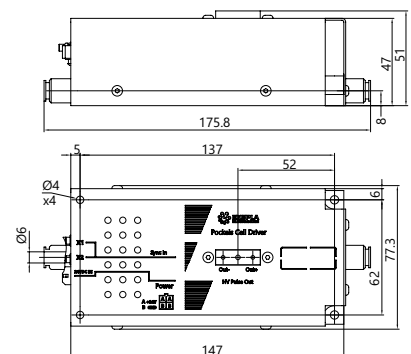

- PCD-UHR-III-500-7.2-C
- PCD-UHR-III-2000-3.4-C
- PCD-UHR-III-2500-3.1-C
- PCD-UHR-III-3000-2.6-C
- 2PCD-UHR-III-4000-1.7-C
- 2PCD-UHR-III-6000-1.3-C

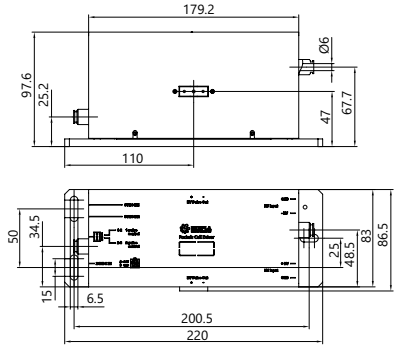

- 2PCD-UHR-500-3.4-C
- 2PCD-UHR-1000-2.4-C
- 2PCD-UHR-2000-1.6-C

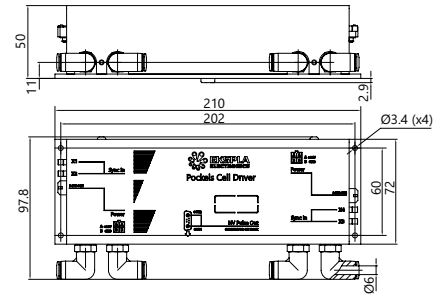

- PCD-UHRS-50-3.6
- PCD-UHRS-250-3.6
- PCD-UHRS-250-2.6
- PCD-UHRS-400-1.5
- PCD-UHRS-500-2.6
- PCD-UHRS-1000-1.8

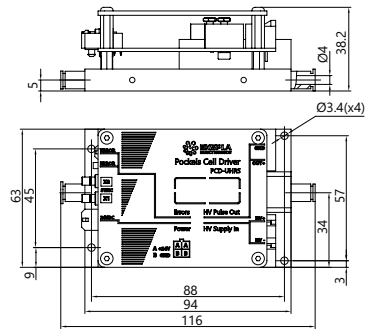

- PCD-UHRS-50-3.6-C-Option1
- PCD-UHRS-250-3.6-C-Option1
- PCD-UHRS-500-2.6-C-Option1
- PCD-UHRS-1000-1.8-C-Option1

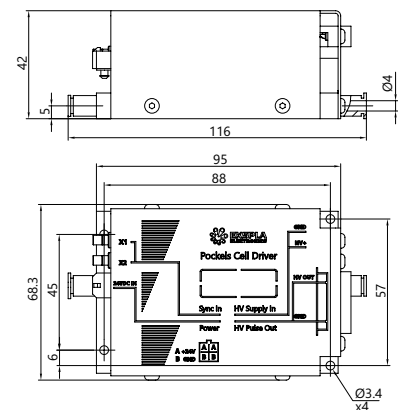

Laser diode drivers

Pockels cell drivers

Pulse and delay generators

Crystal ovens and thermocontrollers

PCD-UHRS-50-3.6-C
 PCD-UHRS-250-3.6-C
 PCD-UHRS-500-2.6-C
 PCD-UHRS-1000-1.8-C

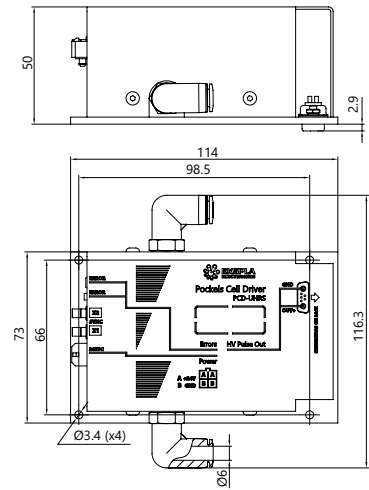

PCD-UHV-4.2
 PCD-UHV-5.5
 PCD-UHV10-8.6
 PCD-UHV10-9.8

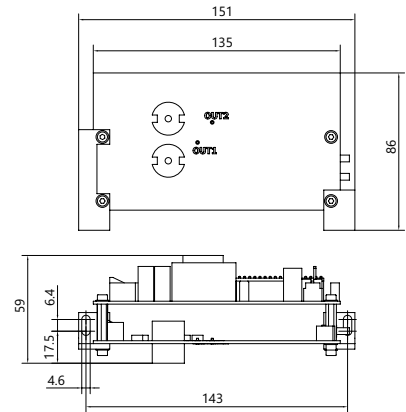

PCD-UHV-4.2-C
 PCD-UHV-5.5-C
 PCD-UHV10-8.6-C
 PCD-UHV10-9.8-C

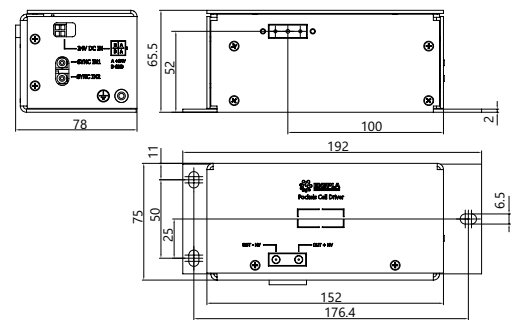

PCD-FAM-250-2.5-C
 PCD-FAM-500-2.5-C

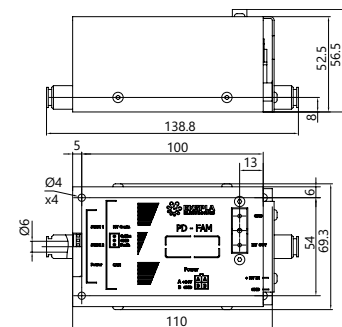

DRAWINGS & IMAGES
OF HV POWER SUPPLIES

HV-200
HV-400
HV-2x200

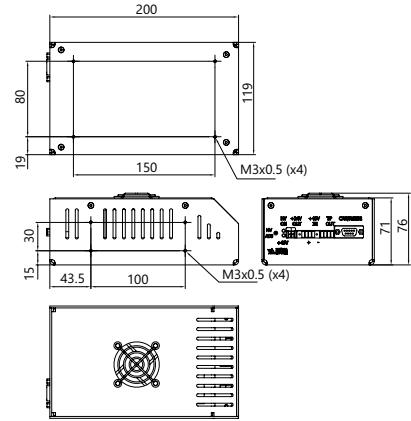

HV-170
HV-2x85

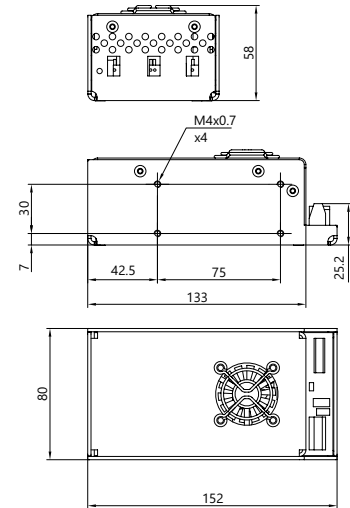

HV05Wm
HV05Wm-CAN

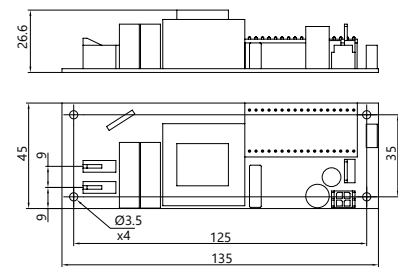
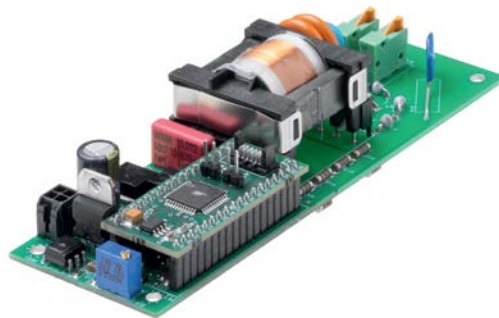

HV40Wm
HV40Wm-CAN

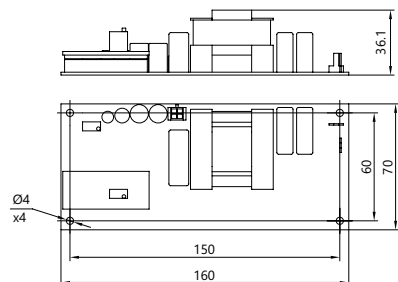

Laser diode drivers

Pockels cell drivers

Pulse and delay generators

Crystal ovens and thermocontrollers

HV80Wm
HV80Wm-CAN

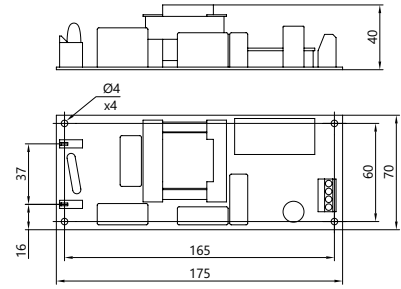

HV120Wm
HV120Wm-CAN
HV2x60Wm
HV2x60Wm-CAN

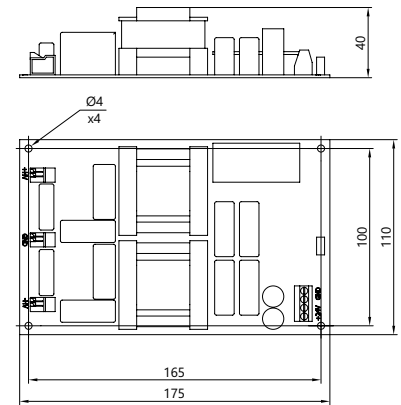

Digital Delay Generator

SY4000

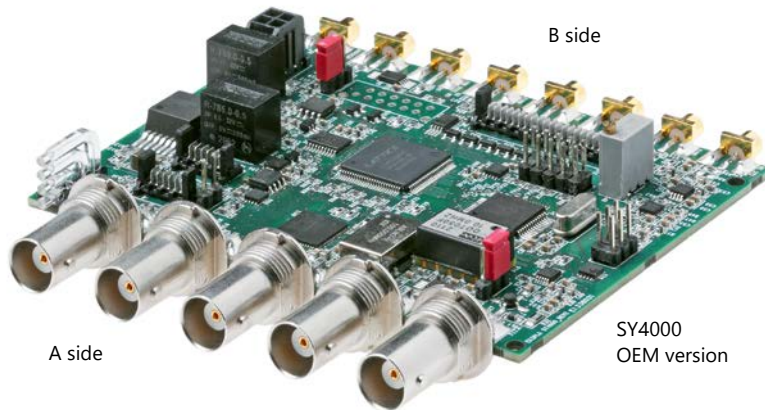

The Ekspla's digital delay generator SY4000 is designed to create up to 8 delayed output pulse sequences precisely synchronized with the internal or external clock. Digital delay generators can provide precise delays for triggering, syncing, delaying, and gating events.

Our SY4000 digital delay generator is mainly employed for synchronization and control of different laser components: AOM drivers, Pockels cell drivers, laser diode drivers, flash lamp drivers, photodetectors, data acquisition systems, etc.

Ekspla can provide both encased and OEM versions of SY4000 digital delay generator. The encased digital delay

generator version can be controlled via RS232, USB, LAN, WLAN and also contains a user-friendly configuration software as well as an internal power supply. These communication options as well as software are also available in SY4000 digital delay generator's OEM version and can be reached by adding additional Ekspla's OEM communication board upon customer's request. The encased digital delay generator is an optimal solution for laboratory use while SY4000 OEM version is ideal for integration and is frequently paired with an additional Ekspla's OEM communication board.



SY4000 desktop version

FEATURES

- ▶ 8 independent output channels
- ▶ Ultra-stable internal clock 0.2 ppm
- ▶ Precise delay/pulse width control in range 2 ns to 150 ms
- ▶ 25 ps timing resolution
- ▶ Hi-accuracy synchronization (locking) to external pulse train
- ▶ Jitter < 30 ps
- ▶ DAC/AWG output
- ▶ Both 50 Ω (6 outs) and differential (8 outs) outputs present
- ▶ Frequency divider / Burst (software and hardware triggered) / Gating / Single shot
- ▶ Communications:
 - OEM version – CAN BUS
 - Encased version – LAN, WIFI (optional), RS232, USB (VCP) – via REST API or DLL's.

APPLICATIONS

- ▶ Mode locked and Q-switched fs, ps & ns lasers
- ▶ Triggering of a data acquisition system
- ▶ General purpose pulse generator
- ▶ Precise system clock source
- ▶ Laser pulse train conversion into a clean clock source
- ▶ All functions above at once

SPECIFICATIONS ¹⁾

Model	SY4000
OUTPUT SPECIFICATIONS (GENERAL)	
Channel modes	Single shot, burst, normal, duty cycle, frequency divider
Delay range	0 to 150 ms
Negative delay	-150 ms
Pulsewidth	2 ns to 150 ms
Resolution	25 ps
Accuracy	25 ps + 0.000001 × delay
Time base	100 MHz, 0.2 ppm
Jitter	< 30 ps
Burst mode	1 to 65535
Output level	2.5 V, 4 V
Impedance	50 Ω
Slew rate	1.5 V/ns
OUTPUT SPECIFICATIONS (INTERNAL GENERATOR)	
Mode	Duty cycle
Rate	50 ns to 100 sec
Resolution	10 ns or 300 ps
Accuracy	5 ns + 0.000001 × period
Jitter	100 ps RMS
Burst	0 ... 65535
INPUT SPECIFICATION (EXTERNAL TRIGGER)	
Rate	DC to 20 MHz
Threshold	1.3 V
Input level	LVTTTL, TTL
Slope	rising
Jitter	< 100 ps RMS
Delay	< 13 ns; < 70 ns
COMMUNICATION OPTIONS	
Control interfaces (OEM board)	CAN by default. RS232, USB, LAN, WLAN with additional communication board, provided upon request
Control interfaces (encased version)	CAN, RS232, USB, LAN, WLAN
POWER REQUIREMENTS	
Power supply requirements (OEM board)	12 V DC, 500 mA
Power supply requirements (encased version)	90...264 V, 50–60 Hz
DIMENSIONS (NOT INCLUDING CONNECTOR)	
OEM board (L × W × H)	100 × 77 × 20 mm
Encased version (L × W × H)	105 × 86 × 85 mm
ACCESORIES	
CAN-USB adapter	Ekspla's CAN-USB adapter is required at evaluation stage for SY4000 OEM version board if communication via CAN interface is needed. Cable between adapter and board and between adapter and PC are included by default
Communication board	Ekspla's communication board which allows to control SY4000 OEM board via RS232, USB, LAN, WLAN interfaces. Can be provided upon request
Input power cables	Included by default

¹⁾ Due to continuous improvement, all specifications are subject to change without notice. Parameters marked typical are not specifications. They are indications of typical performance and will vary with each unit we manufacture.

HIGHLIGHT FUNCTIONS OF EKSPLA'S SY4000 DIGITAL DELAY GENERATOR

- ▶ **Locking to an external clock source** (typically photo-diode pulse train). Triggering system is locked to the laser oscillator and trigger time is always in phase with the optical pulse.
- ▶ **Trigger rate control and limiter circuit.** It helps to protect laser components from damage due to exceedingly high/low triggering rates.
- ▶ **Single ended and differential outputs.**
- ▶ **Instant switch between two configurations in delay blocks.** Burst counter, gate input, frequency divider or software commands may serve as the configuration switching signal sources. Configuration switch is used to control optical pulse pickers (EO or AOM) in a highly flexible manner.
- ▶ **Low jitter sync pulse output** used for high-speed acquisition systems like streak camera triggering. Typical jitter is 3...5 ps with the respect to the optical pulse.
- ▶ **Control connector.** Software-controllable multiplexer may divert any of the output signals to this connector to monitor what is on other connectors without disturbing them.
- ▶ **Clock output: 1:1, 1:2 frequency.**
- ▶ **Up to 4 pulse outputs can be combined** to single signals by OR, AND, NOT logical operations.
- ▶ **DAC output,** controlling, e.g. AOM pass though.

INPUT/OUTPUT SIGNAL DESCRIPTION



COAXIAL CONNECTORS, A-SIDE, BNC TYPE

Name	Description	Amplitude	Pulse parameters	Shape
PRET OUT	Precise trigger, locked to the optical clock. Delay is adjustable in optical clock period time units. Jitter in respect to the optical pulse is ~4 ps RMS, almost independent on delay	>1 V on 50 Ω, AC output, capacitor @ output	Rise time ~200 ps, width adjustable >100 ns	Positive pulse
TRIG1 OUT	General purpose or control sync out	2.5 V @ 50 Ω	Select-able multiplexer to OUT0...OUT8 blocks, Optical clock, Optical clock/2	Logic level or pulse with programmable timing
CM TRIG OUT	Common trigger, general purpose output	2.5 V @ 50 Ω	OUT0 block, programmable pulse parameters	Logic level or pulse with programmable timing
SYNC IN	External synchronization input. Trigger or Configuration switch source	LVTTTL 0.1 mA pull down to low level	Frequency ≤ 100 MHz, PW ≥ 10 ns	Positive pulse
GATE IN	Burst trigger or configuration switch control functions	LVTTTL, 0.1 mA pull down to low level	Level or pulse with PW > 20 ns	Level or pulse

A-SIDE BNC CONNECTORS

Name	Direction	Logic levels	Impedance	Function
PRET OUT	Output	>1.5 V @ 50 Ω	50 Ω	Precision trigger, configurable source
TRIG1 OUT	Output	2.5 V @ 50 Ω, 4.5 V @ 50 Ω jumper configurable	50 Ω	General trigger, configurable source
CM TRIG OUT	Output	2.5 V @ 50 Ω, 4.5 V @ 50 Ω jumper configurable	50 Ω	Master trigger, OUT0 signal
SYNC IN	Input	LVTTTL, tolerates 5 V	0.2 mA pull down	Trigger input
GATE IN	Input	LVTTTL, tolerates 5 V	0.2 mA pull down	Configuration switch and burst control input



COAXIAL CONNECTORS, B-SIDE, MCX TYPE

Name	Description	Amplitude	Pulse parameters	Shape
AN OUT	DAC output	0...1 V	N/A	Two programmable analog levels
CM TRIG OUT	Common trigger, general purpose output	2.5 V @ 50 Ω	OUT0 block	Logic level or pulse with programmable timing
CM TRIG OUT1	Common trigger, general purpose output	2.5 V @ 50 Ω	OUT0 block	Logic level or pulse with programmable timing
OUT2	General purpose output	2.5 V @ 50 Ω	OUT2 block, AND+OR+NOT logic with OUT1	Logic level or pulse with programmable timing
OUT3	General purpose output	2.5 V @ 50 Ω	OUT3 block, AND+OR+NOT logic with OUT2	Logic level or pulse with programmable timing
OUT4	General purpose output	2.5 V @ 50 Ω	OUT4 block, AND+OR+NOT logic with OUT3	Logic level or pulse with programmable timing
OUT5	General purpose output	2.5 V @ 50 Ω	OUT5 block, AND+OR+NOT logic with OUT4	Logic level or pulse with programmable timing
CLC IN	External clock input	>100 mV	PW >300ps, input frequency 10...100 MHz	Sine, Meander to pulse train from photodiode

B-SIDE MCX CONNECTORS

Name	Direction	Logic levels	Impedance	Function
AN OUT	Output	1 V @ 50 Ω max	50 Ω	DAC analog output signal
CM TRIG OUT	Output	2.5 V @ 50 Ω, 4.5 V @ 50 Ω jumper configurable	50 Ω	Master trigger, OUT0 signal
CM TRIG OUT1	Output	2.5 V @ 50 Ω, 4.5 V @ 50 Ω jumper configurable	50 Ω	Master trigger, OUT0 signal
OUT2	Output	2.5 V @ 50 Ω, 4.5 V @ 50 Ω jumper configurable	50 Ω	General purpose trigger, OUT2 signal
OUT3	Output	2.5 V @ 50 Ω, 4.5 V @ 50 Ω jumper configurable	50 Ω	General purpose trigger, OUT3 signal
OUT4	Output	2.5 V @ 50 Ω, 4.5 V @ 50 Ω jumper configurable	50 Ω	General purpose trigger, OUT4 signal
OUT5	Output	2.5 V @ 50 Ω, 4.5 V @ 50 Ω jumper configurable	50 Ω	General purpose trigger, OUT5 signal
CLC IN	Input	0.5 V...3.3 V pk-pk, sine or pulses	50 Ω	Clock input

DRAWINGS

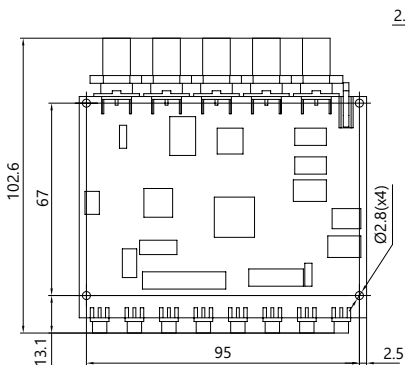

Outline drawings of SY4000 OEM version

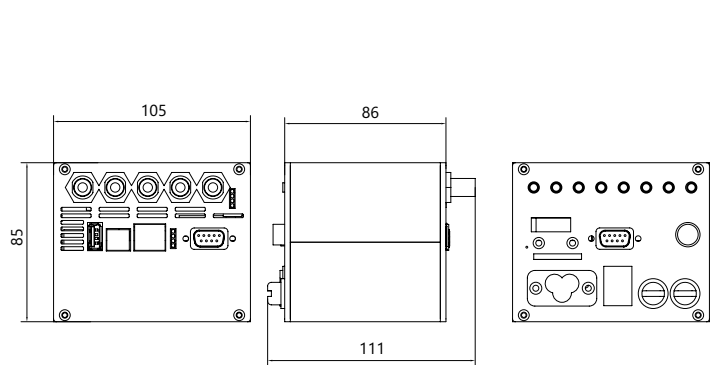

Outline drawings of SY4000 desktop version

Crystal Oven & Thermocontroller

KK1 & TK2 SERIES



Thermocontroller TK2

KK1 crystal oven and TK2 external thermocontroller form an optimal set for precise nonlinear crystal's temperature control up to 200 °C. The KK1+TK2 crystal oven and thermocontroller duo is designed for a wide range of nonlinear crystals: KTP, LBO, CLBO, BBO, KDP, DKDP, LiNbO₃. These nonlinear crystals are used for frequency conversion of a laser beam for SHG, THG, OPO, SFG and DFG applications. KK1+TK2 crystal oven and thermocontroller set ensures efficient phase matching, mitigation of water absorption and prevention of absorption peaks in nonlinear crystals.

The external thermocontroller TK2 has two independent outputs and can control up to two KK1 30 ovens simultaneously. The thermocontroller is equipped with LAN and USB control interfaces and an internal

power supply. The nonlinear crystal is mounted into an adapter before being inserted into the oven KK1. A unique spring-loaded adapter design ensures effortless insertion and replacement of the crystal. The nonlinear crystal can be covered from both ends with fused silica windows for extra protection upon customer's request. The standard adapters can be either 30 mm or 50 mm long with apertures up to 12×12 mm. KK1 crystal oven by default contains one adapter for the specific crystal size. Each adapter is designed specifically for a given crystal aperture size and cannot accommodate different-sized crystals. Adapters for crystals of different sizes can be ordered separately. Additionally, Ekspla can also provide adapter H4 for KK1 crystal oven's mounting on a tilt stage.

FEATURES

- ▶ High heating temperature (up to 200 °C)
- ▶ High temperature accuracy (± 0.5 °C)
- ▶ Effortless insertion spring-loaded adapter
- ▶ Extra-safe fused silica windows option
- ▶ Robust crystal oven's design

APPLICATIONS

- ▶ Frequency conversion of a laser beam for SHG, THG, OPO, SFG and DFG



Crystal oven KK1-30



Thermocontroller TK2 front side



Thermocontroller TK2 back side

SPECIFICATIONS ¹⁾

Model	TK2 + KK1-30	TK2 + KK1-50
Temperature range	From room temperature to 200 °C	
Maximum crystal dimensions	12×12×30 mm	12×12×50 mm
Temperature tuning step	0.05 °C	
Accuracy	± 0.5 °C	
Long-term stability	± 0.05 °C	
Control interfaces	LAN, USB	
Power supply requirements	90 – 264 V, 47 – 63 Hz	
Power consumption	< 50 W	
Oven dimensions, Dia×D	Ø52×52 mm	Ø52×72 mm
Quantity of ovens possible to connect to one controller TK2	2	1
Accessories	Wall plug power supply (included by default), H4 mounting adapter (included upon request)	

¹⁾ Due to continuous improvement, all specifications are subject to change without notice. Parameters marked typical are not specifications. They are indications of typical performance and will vary with each unit we manufacture.

DRAWINGS

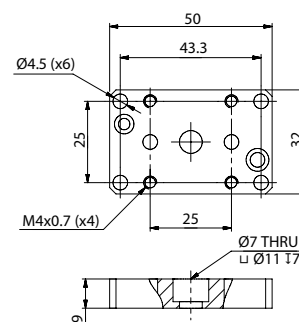
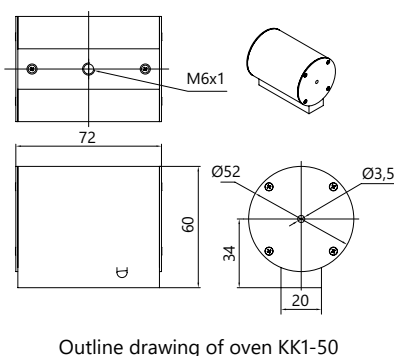
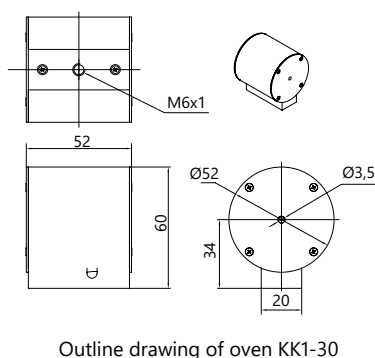
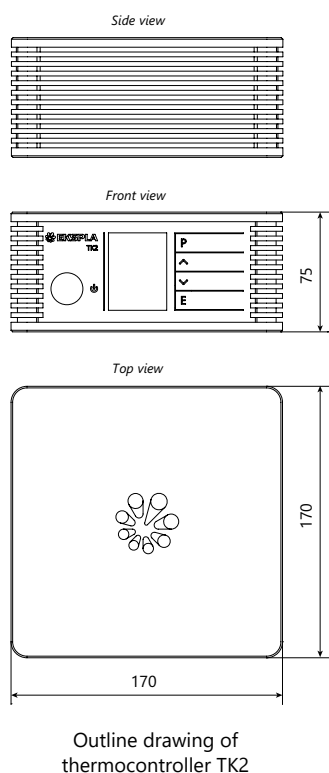

Nonlinear Crystal Oven with built-in Thermocontroller

TK8 SERIES

Oven TK8

TK8 crystal oven with an internal thermocontroller is an optimal device for precise nonlinear crystal temperature control from room temperature up to 80 °C. The TK8 crystal oven is designed for a wide range of nonlinear crystals: KTP, LBO, CLBO, BBO, KDP, DKDP, LiNbO₃. These nonlinear crystals are used for frequency conversion of a laser beam for SHD, THD, OPO, SFG and DFG

applications. TK8 crystal oven ensures efficient phase matching, mitigation of water absorption and prevention of absorption peaks in nonlinear crystals.

TK8 crystal oven, with an internal thermocontroller, can fit crystals with apertures up to 15×15 mm and lengths up to 20 mm. TK8L and TK8XL ovens are designed for crystals up to 30 mm and 50 mm long. Each oven is specifically designed for a given

FEATURES

- ▶ Internal thermocontroller
- ▶ Custom crystal apertures up to 60 x 60 mm or more
- ▶ High temperature (up to 80 °C)
- ▶ High accuracy (± 0.5 °C)
- ▶ Digital control (via CAN)

APPLICATIONS

- ▶ Frequency conversion of a laser beam for SHG, THG, OPO, SFG and DFG

crystal aperture size and cannot accommodate different-sized crystals. Temperature can be either preset at factory or customer can set it himself while using Ekspla's CAN-USB converter (sold separately) via Ekspla's software (included by default). TK8 crystal ovens can operate either in autonomous or present time modes. Upon request Ekspla can manufacture tailored ovens for crystals with an apertures up to 60 × 60 mm or more.

SPECIFICATIONS ¹⁾

Model	TK8	TK8L	TK8XL
Temperature range	From room temperature to 80 °C		
Maximum crystal dimensions ²⁾	15×15×20 mm	15×15×30 mm	15×15×50 mm
Temperature tuning step	0.01 °C		
Accuracy	± 0.5 °C		
Long-term stability	± 0.05 °C		
Control interfaces	CAN		
Supply voltage	12 – 24 V		
Power consumption	< 6 W	< 6 W	< 9 W
Oven dimensions, W×H×D	48×44×26 mm	48×44×36 mm	48×44×56 mm
Crystal center position above pad	16 mm		
Accessories	Wall plug power supply (included by default), Ekspla's CAN-USB adapter (included upon request), H1 mountig stage (included upon request)		

¹⁾ Due to continuous improvement, all specifications are subject to change without notice. Parameters marked typical are not specifications. They are indications of typical performance and will vary with each unit we manufacture.

²⁾ Crystal holder's aperture can be customized to fit crystals up to 60×60 mm or more.

DRAWINGS

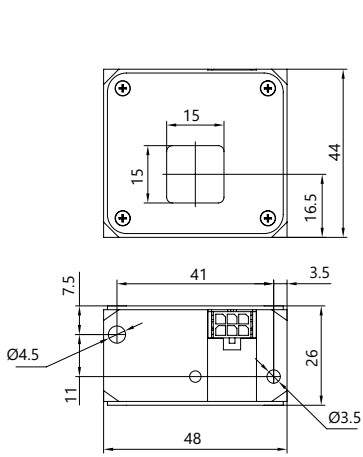

Outline drawings of TK8

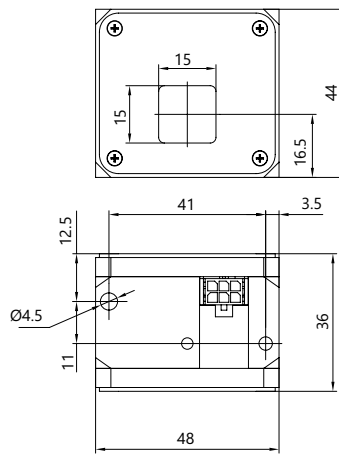

Outline drawings of TK8L

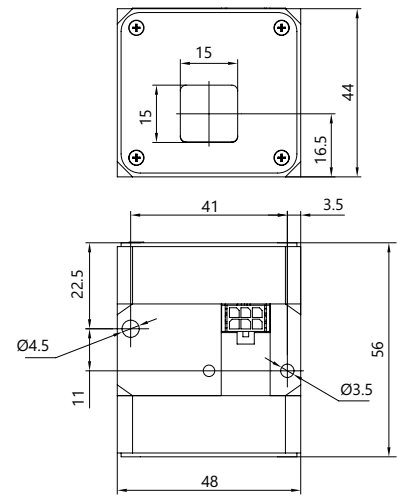

Outline drawings of TK8XL

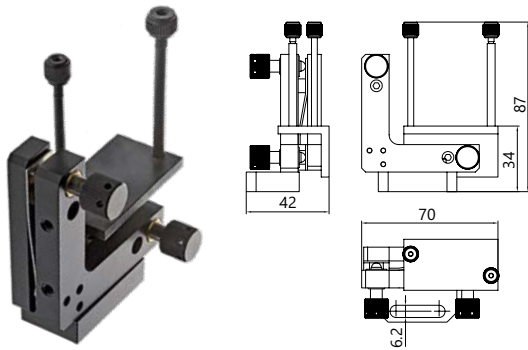

Mount H1 for fine tuning of TK8 crystal ovens angle.
The tuning range is $\pm 2.5^\circ$

Ordering Information

Delivery	Products are made and dispatched within agreed term. Shipping charges are object of agreement between EKSPLA and customer.
Ordering	Orders may be placed by mail, fax or e-mail. All orders are object of General Sales Conditions, which can be found on www.ekspla.com . Mail orders should be sent to: EKSPLA, UAB Savanoriu Av. 237 LT-02300 Vilnius Lithuania Phone: +370 5 264 96 29 E-mail: sales@ekspla.com Ask for quotation online at www.ekspla.com.
Certificate of Origin	All items shown in this catalogue are of Lithuanian Origin (EU). Certificate of Origin is available under request.
Warranty	All products are guaranteed to be free from defects in material and workmanship. The warranty period depends on the product and is object of agreement between EKSPLA and customer. Warranty period can be extended by separate agreement. EKSPLA does not assume liability for unproper installation, labour or consequential damages.
Specifications	Due to the constant product improvements, EKSPLA reserves its right to change specifications without advance notice. For latest information visit www.ekspla.com .

Notes

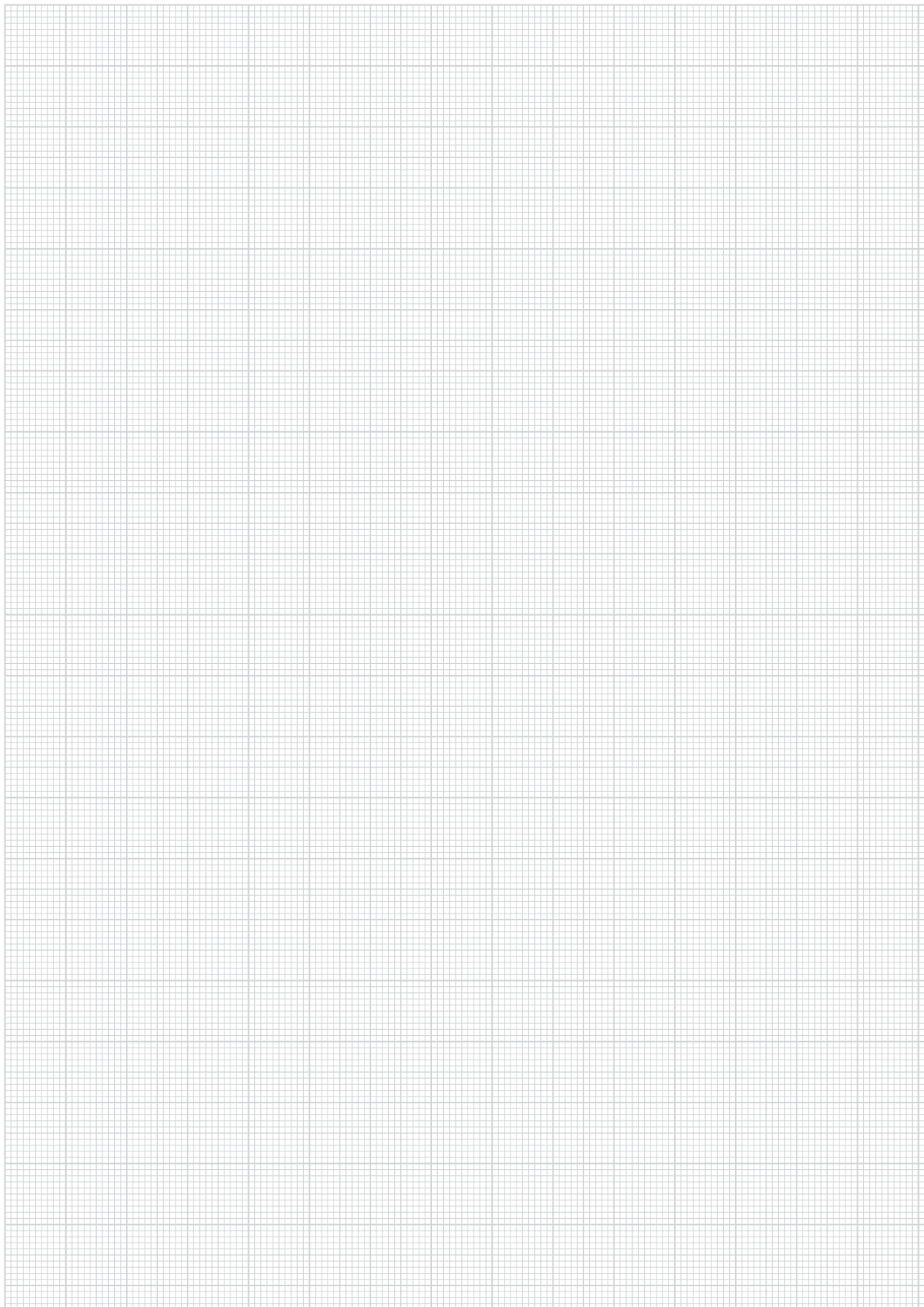

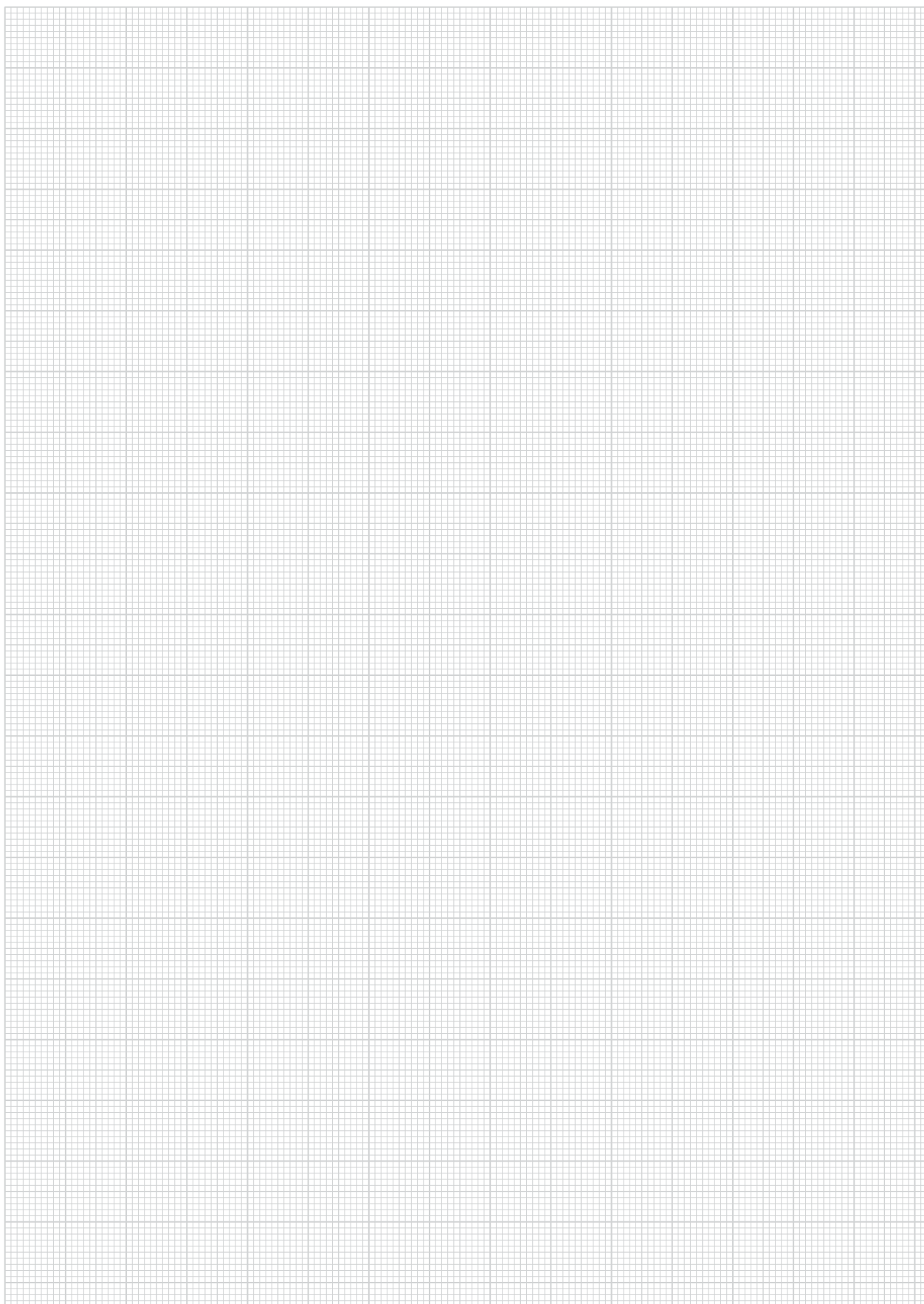



グローバルにネットワークを広げ、最先端の科学をお客様に提供

本社: 〒134-0088 東京都江戸川区西葛西6-18-14 T.I.ビル Tel. 03-3686-4711

営業所: 〒532-0003 大阪府大阪市淀川区宮原4-1-46 新大阪北ビル Tel. 06-6393-7411

URL: <https://www.tokyoinst.co.jp> Mail: sales@tokyoinst.co.jp



超高真空・極低温走査型プローブ顕微鏡
高速分光測定装置、クライオスタット



Nd:YAGレーザー、Ti:Sレーザー
OPOレーザー



Follow us on LinkedIn 



Advanced electronics
technologies

ISO9001 Certified

Find local distributor at
www.ekspla.com



Savanorių Av. 237
LT-02300 Vilnius
Lithuania

ph. +370 5 264 96 29
sales@ekspla.com
www.ekspla.com