



Advanced Laser Technologies

High Intensity Lasers & Laser Systems



Femtosecond

5

Picosecond

20

Nanosecond

32

*from single shot to
kHz repetition rates*

highly customizable

Contents

About Company	2
---------------	---

Femtosecond Lasers & Systems 5

UltraFlux HR High repetition rate Tunable Wavelength Femtosecond OPCPA Systems	5
UltraFlux HE High Energy Femtosecond OPCPA Systems	10
UltraFlux Custom Multi TW Few cycle OPCPA systems	16

Picosecond Lasers & Systems 20

PicoFlux HE High Energy Flash Lamp Pumped Picosecond Amplifiers	20
PicoFlux HP High Repetition Rate Diode Pumped Picosecond Amplifiers	24
PicoFlux Custom Custom Picosecond Amplifiers	28

Nanosecond Lasers & Systems 32

NanoFlux SLM Single Mode (SLM) High Energy Q-switched Nd:YAG Lasers	32
NanoFlux MM Multimode (MM) High Energy Q-switched Nd:YAG Lasers	36
NanoFlux HP High Power Diode Pumped Nanosecond Amplifier Systems	40
NanoFlux AWG Temporally Shaped (AWG) High Energy Nd:YAG Lasers	44

Ordering Information	48
----------------------	----

About Company

Background

EKSPLA focuses on the design and manufacturing of advanced lasers & systems and employs 33 years' experience as well as a close partnership with the scientific community. 80 out of the 100 top universities use EKSPLA lasers.

Customers like CERN, NASA, ELI, Max Planck Institutes, Cambridge University, Massachusetts Institute of Technology and Japan University of Science showed trust in EKSPLA lasers & systems.

For scientist who needs unique instrument for research, we provide parameter tailored laser systems that enable customer to perform complex experiments. In-house design and manufacturing ensures operative design, manufacturing and customization of new products.

Highly stable and reliable EKSPLA lasers combined with our own subsidiaries in the US, UK and China as well as more than 20 approved representative offices with properly trained laser engineers worldwide, ensure short response time and fast laser service as well as maintenance.

History

EKSPLA was founded about 33 years ago by a small team of engineers united around the idea of making the most advanced lasers in the world. EKSPLA was independent company with little money, but lots of creativity, and a deep technical understanding of lasers and how useful they could be for research and industry. From the start, the whole team had a deep mutual respect and believed in and supported each other. The first laser was sold at its first launch event, at an international exhibition in Germany. Soon after, the innovation was noticed by partners in Japan, and supply of the systems to leading universities there has been started. The concept of continuous improvement was admired and embraced, so it has become one of the key principles that apply to everything is done.

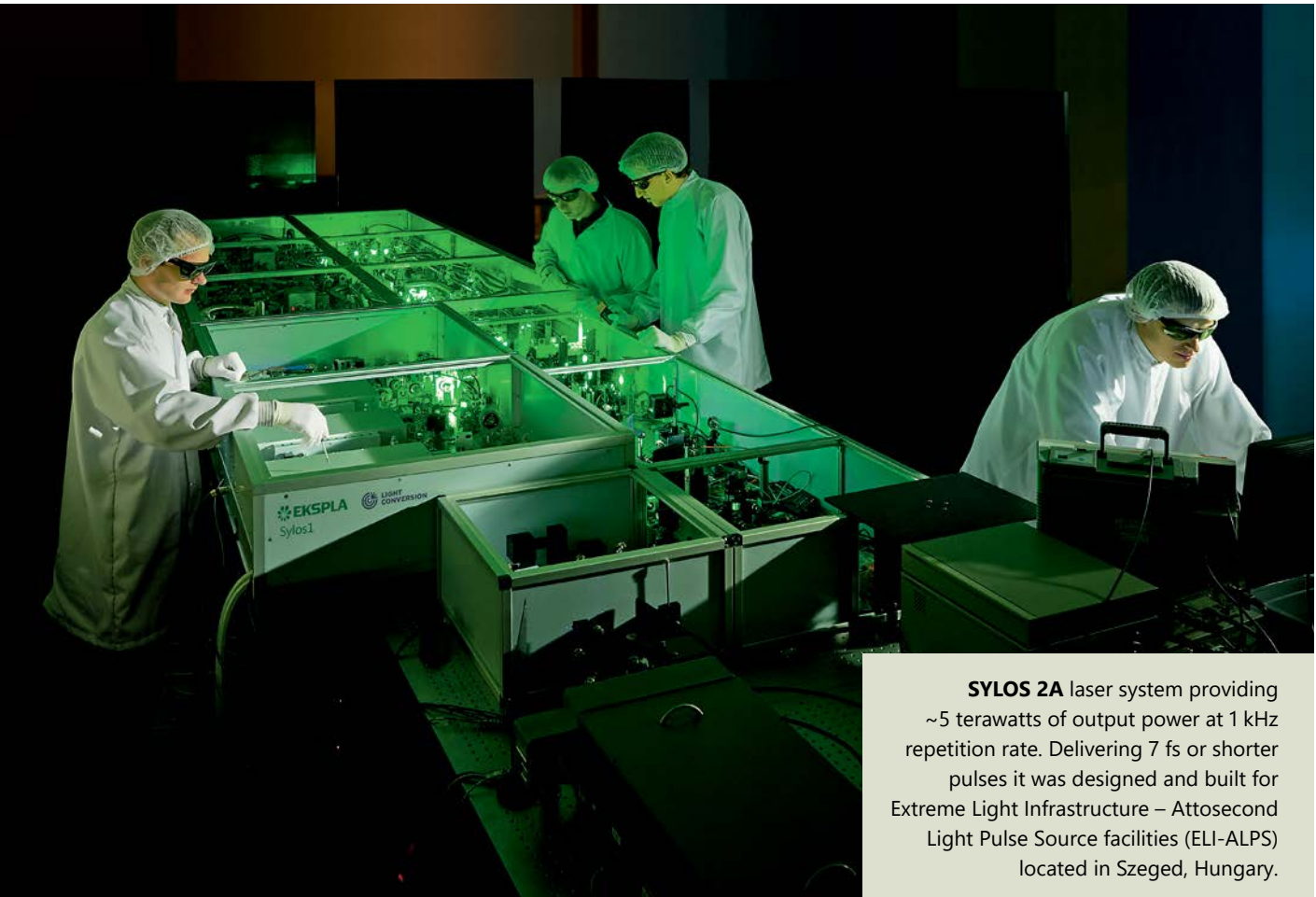

SYLOS 2A laser system providing ~5 terawatts of output power at 1 kHz repetition rate. Delivering 7 fs or shorter pulses it was designed and built for Extreme Light Infrastructure – Attosecond Light Pulse Source facilities (ELI-ALPS) located in Szeged, Hungary.

SYLOS 3: High-Intensity Leaps in Fundamental Research

The Single Cycle Laser SYLOS, which employs OPCPA technology, has been designed and manufactured by a consortium of two Lithuanian companies – EKSPALA and Light Conversion. Introduced at Vilnius University, OPCPA today is one of the key technologies for generating high-intensity radiation, surpassing conventional femtosecond technology based on Ti:Sapphire lasers in terms of pumping efficiency, contrast, bandwidth, and, consequently, the degree of control over the generated radiation.

The consortium won SYLOS 1 procurement SYLOS 2A upgrade and SYLO S3 tenders.

SYLOS 2A system was installed in 15 May 2019 and produces Carrier Envelope Phase (CEP) stabilized, 6.6 fs laser pulses with a peak power of > 4.5 TW and an average power of 35 W at 1 kHz repetition rate. At that time it was the highest average power produced by a multi-TW few-cycle OPCPA system.

SYLOS 3 system was installed on September, 2023. Compared to the SYLOS 2A system, the new system provides more than three times higher peak and average power. It delivers 15 TW of peak power at a 1 kHz repetition rate and an 8 fs pulse duration. Kilohertz repetition rate enables researchers to collect significantly more data and, thus, improve the efficiency of experiments.

Learn more about custom TW systems on page 16.



Unique Laser Systems for Extreme Applications

Today laser intensities reached levels where relativistic effects dominate in laser-matter interaction. New applications of high pulse energy lasers emerge in various disciplines ranging from fundamental physics to materials research and life sciences. EKSPLA presents line of femtosecond,

picosecond and nanosecond high pulse energy lasers and amplifiers. Our broad knowledge in high energy laser physics, non-linear materials and more that 30 years of experience in laser design enables us to offer unique solutions for high intensity laser systems.

Our high intensity lasers feature flash lamp pump for ultra-high pulse energy, diode pump for high average power. Innovative solutions for pulse shaping, precise synchronization between different laser sources enable to fit these systems to numerous experiments of modern fundamental science.

SHORT SELECTION GUIDE

For Your convenience, table contains a short selection guide and highest parameter values achievable. Not all output specifications are available at the same time simultaneously. Please refer to the catalog page for exact specifications and available options.

Series	Pulse duration	Pulse energy, up to	Repetition rate, up to	Special feature	Page
UltraFlux HR	down to 10 fs	20 mJ	1 kHz	High repetition rate Tunable Wavelength fs OPCPA Systems	5
UltraFlux HE		1 J	100 Hz	High Energy fs OPCPA Systems	10
UltraFlux Custom	down to 8 fs	1 J	1 kHz	Custom multi TW Few cycle OPCPA systems	16
PicoFlux HE	90 ± 10 ps	2.2 J	10 Hz	High energy flash lamp pumped ps amplifiers	24
PicoFlux HP		130 mJ	1 kHz	High power DPSS ps amplifiers	24
PicoFlux Custom		2.2 J per channel	10 kHz	Custom multi-channel, burst mode and 1 ps Ytterbium amplifier systems	28
NanoFlux SLM	2 ± 0.5 ns	10 J	10 Hz	High energy Single Longitudinal Mode (SLM) Nd:YAG lasers	32
NanoFlux MM	5 ± 1 ns	10 J	10 Hz	High energy Multi-Mode Nd:YAG lasers	36
NanoFlux HP		5 J	1 kHz	High power DPSS ns amplifier systems	40
NanoFlux AWG	0.15 – 20 ns	10 J	10 Hz	High energy systems with temporal pulse shaping (AWG)	44

High repetition rate Tunable Wavelength Femtosecond OPCPA Systems



UltraFlux HR series is a compact high repetition rate tunable wavelength femtosecond laser system which incorporates the advantages of dual output ultrafast fiber laser, solid-state and parametric chirped pulse amplification technologies.

A novel OPCPA front-end technology uses a dual output picosecond fiber laser for seeding both picosecond DPSS pump laser and femtosecond parametric amplifier with a spectrally broadened output.

This approach greatly simplifies the system – excludes femtosecond regenerative amplifier and eliminates the need of pump and seed pulse synchronization while ensuring practically zero jitter between the channels. In addition to that, contrast of the output pulses in picosecond to nanosecond time scale is enhanced.

All UltraFlux series laser systems are assembled on a rigid breadboard or optical table to ensure excellent long-term stability. Modular internal design offers high level of customization and easy scalability. All of these systems can be customized according to customer requirements by adding custom specifications or multiple channels.

Incorporation of parametric chirped pulse amplification technology together with a novel ultrafast fiber laser helped to create and bring to the market a new tool for femtosecond pump-probe, nonlinear spectroscopy, emerging high harmonic generation experiments and other femtosecond and nonlinear spectroscopy applications. With this laser ultrafast science breakthrough is closer to any photonics lab than ever before.

UltraFlux HR SERIES

FEATURES

- ▶ Based on the novel OPCPA (Optical Parametric Chirped Pulse Amplification) technology
- ▶ Patented front-end design (patents no. EP2827461 and EP2924500)
- ▶ 750 – 960 nm, 375 – 480 nm, 250 – 320 nm and 210 – 230 nm wavelength tuning ranges
- ▶ Up to 14 mJ pulse energy at 1 kHz repetition rate
 - Excellent pulse energy stability: $\leq 1\%$ RMS
 - Excellent long-term average power stability: $\leq 1.5\%$ RMS over 8-hour period
- ▶ Perfectly synchronized fs and ps output option available
- ▶ Hands free wavelength tuning
- ▶ High contrast pulses without any additional improvement equipment

APPLICATIONS

- ▶ Broadband CARS and SFG
- ▶ Femtosecond pump-probe spectroscopy
- ▶ Nonlinear spectroscopy
- ▶ High harmonic generation

SPECIFICATIONS

Model	FT031k	FT31k	FT61k	FT141k
MAIN SPECIFICATIONS ¹⁾				
Output energy ²⁾				
Signal	300 μ J	3 mJ	6 mJ	14 mJ
SH output ³⁾	60 μ J	0.6 mJ	1.5 mJ	3.5 mJ ⁴⁾
TH output ³⁾	15 μ J	150 μ J	0.4 mJ	1.2 mJ ⁴⁾
FH output ³⁾	3 μ J	30 μ J	100 μ J	300 μ J ⁴⁾
Pulse repetition rate	1 kHz	1 kHz	1 kHz	1 kHz
Wavelength tuning range				
Signal ⁵⁾	750 – 960 nm	750 – 960 nm	750 – 960 nm	750 – 960 nm
SH output ³⁾	375 – 480 nm	375 – 480 nm	375 – 480 nm	375 – 480 nm
TH output ³⁾	250 – 320 nm	250 – 320 nm	250 – 320 nm	250 – 320 nm
FH output ³⁾	210 – 230 nm	210 – 230 nm	210 – 230 nm	210 – 230 nm
Scanning steps				
Signal	5 nm	5 nm	5 nm	5 nm
SH output ³⁾	5 nm	5 nm	5 nm	5 nm
TH output ³⁾	3 nm	3 nm	3 nm	3 nm
FH output ³⁾	2 nm	2 nm	2 nm	2 nm
Pulse duration ^{5) 7)}	40 \pm 20 fs	40 \pm 20 fs	40 \pm 20 fs	40 \pm 20 fs
Pulse energy stability ⁸⁾	\leq 1.5 %	\leq 1 %	\leq 1 %	\leq 1 %
Long-term power drift ⁹⁾	\pm 1.5 %	\pm 1.5 %	\pm 1.5 %	\pm 1.5 %
Beam spatial profile	Gaussian	Super-Gaussian ¹⁰⁾	Super-Gaussian ¹⁰⁾	Super-Gaussian ¹⁰⁾
Beam diameter ¹¹⁾	\sim 2 mm	\sim 5 mm	\sim 7 mm	\sim 15 mm
Beam pointing stability ¹²⁾	\leq 20 μ rad	\leq 20 μ rad	\leq 20 μ rad	\leq 20 μ rad
Temporal contrast ¹³⁾				
APFC (within \pm 50 ps)	$>$ 10 ¹⁰ : 1	$>$ 10 ¹⁰ : 1	$>$ 10 ¹⁰ : 1	$>$ 10 ¹⁰ : 1
Pre-pulse (50 – 10 ps)	$>$ 10 ⁸ : 1	$>$ 10 ⁸ : 1	$>$ 10 ⁸ : 1	$>$ 10 ⁸ : 1
Pre-pulse (10 – 1 ps)	$>$ 10 ⁶ : 1	$>$ 10 ⁶ : 1	$>$ 10 ⁶ : 1	$>$ 10 ⁶ : 1
Post-pulse (beyond 20 ps)	$>$ 10 ⁶ : 1	$>$ 10 ⁶ : 1	$>$ 10 ⁶ : 1	$>$ 10 ⁶ : 1
Optical pulse jitter ¹⁴⁾				
Trig out	\leq 100 ps	\leq 100 ps	\leq 100 ps	\leq 100 ps
Pre-Trig out	\leq 50 ps	\leq 50 ps	\leq 50 ps	\leq 50 ps
With –PLL option	\leq 2 ps	\leq 2 ps	\leq 2 ps	\leq 2 ps
Polarization	Linear, Horizontal	Linear, Horizontal	Linear, Horizontal	Linear, Horizontal
PHYSICAL CHARACTERISTICS ¹⁵⁾				
Laser head size (W×L×H mm)	750 × 1200 × 300	900 × 1500 × 300	900 × 1800 × 300	1200 × 2000 × 300
Power supply size (W×L×H mm)	553 × 600 × 850	553 × 600 × 850	553 × 600 × 850	553 × 600 × 1250
Umbilical length ¹⁶⁾	2.5 m	2.5 m	2.5 m	2.5 m
OPERATING REQUIREMENTS ¹⁷⁾				
Electrical power	200 – 240 V AC, single-phase, 47 – 63 Hz	200 – 240 V AC, single-phase, 47 – 63 Hz	208, 380 or 400 V AC, three-phase, 50/60 Hz ¹⁸⁾	208, 380 or 400 V AC, three-phase, 50/60 Hz ¹⁸⁾
Power consumption ¹⁹⁾	\leq 1 kW	\leq 2 kW	\leq 5 kW	\leq 8 kW
Water supply	not required	not required	not required	\leq 5 l/min, 2 Bar, max 20 °C
Operating ambient temperature	22 \pm 2 °C	22 \pm 2 °C	22 \pm 2 °C	22 \pm 2 °C
Storage ambient temperature	15 – 35 °C	15 – 35 °C	15 – 35 °C	15 – 35 °C
Relative humidity (non-condensing)	\leq 80 %	\leq 80 %	\leq 80 %	\leq 80 %
Cleanness of the room	ISO Class 7	ISO Class 7	ISO Class 7	ISO Class 7

¹⁾ Due to continuous improvement, all specifications are subject to change without notice. The parameters marked 'typical' are indications of typical performance and will vary with each unit we manufacture. Presented parameters can be customized to meet customer's requirements.

²⁾ Maximum pulse energy specified at 840 nm, SH output at 420 nm, TH output at 280 nm and FH output at 210 nm.

³⁾ Harmonic outputs are optional. Specifications valid with respective harmonic module purchased. Outputs are not simultaneous. Maximum harmonic energy depends on OPCA signal beam profile and pulse duration.



- 4) Maximum pump energy for harmonics limited to 10 mJ @ 840 nm.
- 5) Optional extended tuning range of 700 – 1010 nm available upon request.
- 6) Standard pulse duration changes though the wavelength range – shortest pulse duration is achieved ~840 nm spectral range.
- 7) Separate 'F10' option can be ordered to reduce pulse duration to ≤ 10 fs. Wavelength tunability not available with 'F10' option.
- 8) Under stable environmental conditions, normalized to average pulse energy (RMS, averaged from 60 s).
- 9) Measured over 8 hours period after 30 min warm-up when ambient temperature variation is less than ± 2 °C.
- 10) Super-Gaussian spatial mode of 6-11th order in near field.
- 11) Beam diameter is measured at signal output at $1/e^2$ level for Gaussian beams and FWHM level for Super-Gaussian beams.

- 12) Beam pointing stability is evaluated as movement of the beam centroid in the focal plane of a focusing element (RMS, averaged from 30 s).
- 13) Pulse contrast is only limited by amplified parametric fluorescence (APFC) in the temporal range of ~90 ps which covers OPCPA pump pulse duration and is better than $10^7:1$. APFC contrast depends on OPCPA saturation level. Our OPCPA systems are ASE-free and pulse contrast value in nanosecond range is limited only by measurement device capabilities (third-order autocorrelator). There are no pre-pulses generated in the system and post-pulses are eliminated by using wedged transmission optics.
- 14) Optical pulse jitter with respect to electrical outputs:
 - Trig out > 3.5 V @ 50 Ω
 - Pre-Trig out > 1 V @ 50 Ω
 - PLL option > 1 V @ 50 Ω

- 15) System sizes are preliminary and depend on customer lab layout and additional options purchased.
- 16) Longer umbilical with up to 10 m for flash lamp pumped and up to 5 m for diode pumped systems available upon request.
- 17) The laser and auxiliary units must be settled in such a place void of dust and aerosols. It is advisable to operate the laser in air conditioned room, provided that the laser is placed at a distance from air conditioning outlets. The laser should be positioned on a solid worktable. Access from one side should be ensured.
- 18) Voltage fluctuations allowed are +10 % / -15 % from nominal value.
- 19) Required current rating can be calculated by dividing power rating by mains voltage. Power rating is given in apparent power (kVA) for systems with flash lamp power supplies and in real power (kW) for systems without flash lamp power supplies where reactive power is neglectable.

OPTIONS

Option	Description	Comment
-F10	Short Pulse option reduces output pulse duration to ≤ 10 fs	Wavelength tunability not available with 'F10' option
-CEP	CEP stabilization to ≤ 400 mrad	Passive and active CEP stabilization
-DM	'Deformable Mirror' option for Strehl ration improvement to > 0.9	
-SH/TH/FH	Second, third and fourth harmonic outputs	Conversion efficiency from signal respectively ~20 %, ~5 % and ~1 %. Harmonic outputs are not simultaneous with signal output
-ps out	Additional ps output that is optically synchronized to main system output	Can be simultaneous and non-simultaneous to the main system output
-AW	Air-Water cooling	No external water required. Heat dissipation equals total power consumption

PERFORMANCE

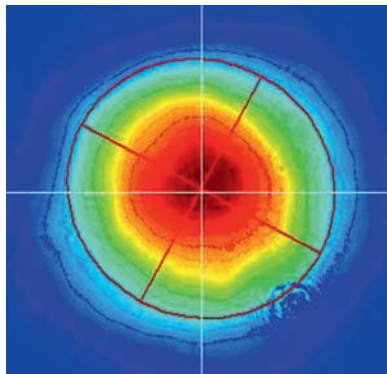

Fig 1. Typical UltraFlux FT031k near field beam profile

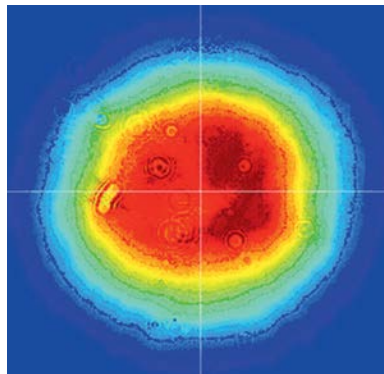

Fig 2. Typical UltraFlux FT31k near field beam profile

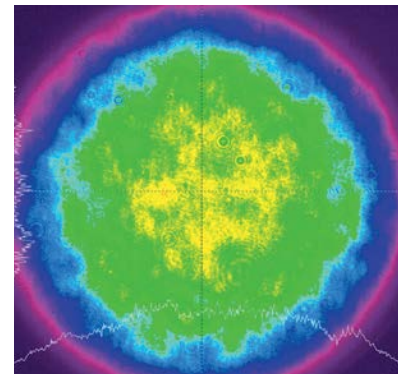

Fig 3. Typical UltraFlux FT61k and FT141k near field beam profile

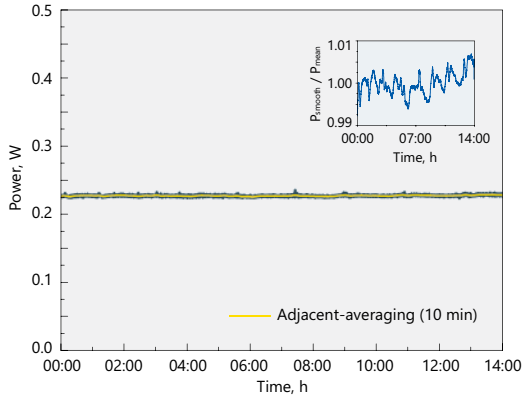

Fig 4. Long-term power stability measurement at 800 nm wavelength

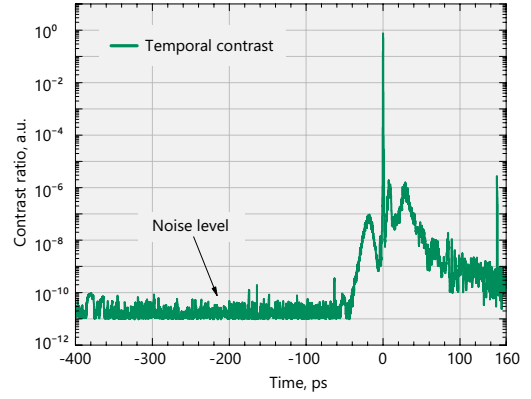

Fig 5. Typical temporal contrast of UltraFlux systems

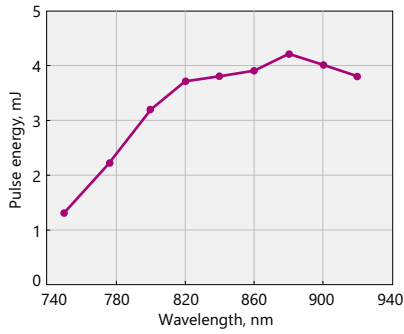

Fig 6. Typical energy tuning curve of UltraFlux FT31k laser system

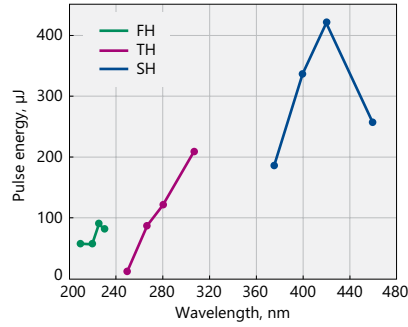

Fig 7. Typical energy tuning curves of UltraFlux FT31k second, third and fourth harmonic outputs

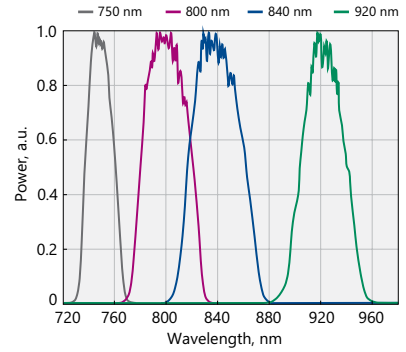

Fig 8. Typical output spectra of UltraFlux FT31k system at multiple wavelengths



Fig 9. Typical external view of UltraFlux FT031k system (actual design might vary)

OUTLINE DRAWINGS

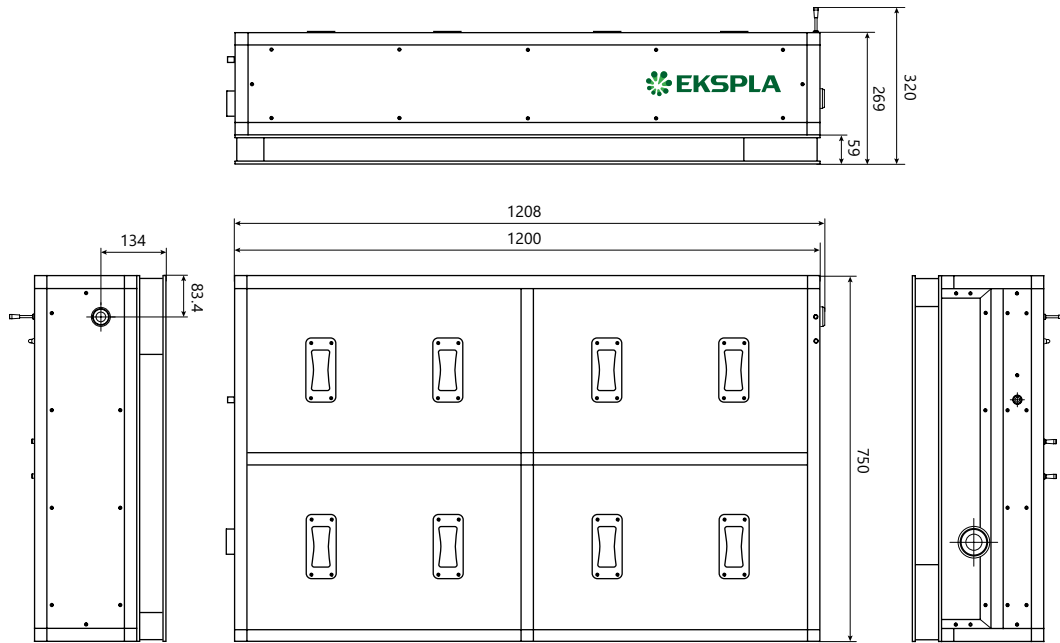

Fig 10. Typical UltraFlux FT031k laser system external dimensions

POWER SUPPLY

Cabinet	Usable height	Height H, mm	Width W, mm	Depth D, mm
MR-9	9 U	455.5 (519 ¹⁾)	553	600
MR-12	12 U	589 (653 ¹⁾)	553	600
MR-16	16 U	768 (832 ¹⁾)	553	600
MR-20	20 U	889 (952 ¹⁾)	553	600
MR-25	25 U	1167 (1231 ¹⁾)	553	600

¹⁾ Full height with wheels.

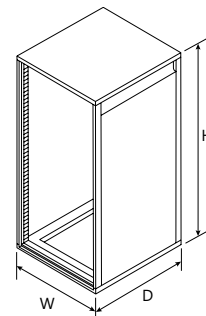

Fig 11. Typical UltraFlux laser system power supply dimensions (MR rack used depends on the laser model)

ORDERING INFORMATION

Note: Laser must be connected to the mains electricity all the time. If there will be no mains electricity for longer than 1 hour then laser (system) needs warm up for a few hours before switching on.

UltraFlux (1) (2)(3)-(4)

Fixed or tunable wavelength:
 FF → fixed wavelength
 FT → tunable wavelength

Any additional options:
 See 'Options' table

Pulse repetition rate:
 1k → 1 kHz

Energy level:
 03 → 300 μJ
 3 → 3 mJ
 6 → 6 mJ
 14 → 14 mJ

High Energy Femtosecond OPCPA Systems



UltraFlux FF. Custom high pulse energy femtosecond fixed wavelength laser systems delivering up to 1 J pulse energy with pulse duration down to 10 fs.

High Energy UltraFlux laser series delivers up to **30 TW** peak power operating up to 10 Hz.

Originally built for ELI-ALPS (Extreme Light Infrastructure – Attosecond Light Pulse Source) in Hungary, this series is now available for a wide variety of applications.

The master oscillator is a patented (no. EP2827461 and EP2924500) all-in-fiber Yb doped picosecond laser seed source with two fiber outputs. One seeds the OPCPA Front-End and another seeds the Picosecond Pump Laser. Both outputs originate from the same fiber so they are optically synchronized.

This approach eliminates the need for a complex temporal synchronization system typically present in other OPCPA systems.

The Nd:YAG Picosecond Pump Laser system (PPL) is comprised of several sub-systems: diode pumped Regenerative Amplifier, diode pumped Preamplifier, flash lamp pumped Amplifiers, and Second Harmonic Generators which convert

fundamental 1064 nm wavelength to 532 nm. PPL outputs multiple beams at 532 nm. One beam is directed to NOPCPA Front-End subsystem and others are directed to NOCPA amplification stages.

The Front-End NOPCPA (Non-collinear Optical Parametric Chirped Pulse Amplifier) consists of several sub-systems: Picosecond Optical Parametric Amplifier (ps-OPA) amplifying oscillator output pulses, Grating Compressor compressing ps-OPA output pulses, White Light Generator (WLG) broadening the spectrum of ps-OPA output pulses and Femtosecond Non-collinear Optical Parametric Amplifier (fs-NOPA) amplifying WLG output pulses.

The Stretcher sub-system is a Grism (diffraction gratings combined together with prisms) or Offner type pulse stretcher, which stretches output pulse from NOPCPA Front-End and Dazzler (optional Acousto-Optic Programmable Dispersive Filter) for high order phase compensation.

UltraFlux HE SERIES

FEATURES

- ▶ Based on the novel **OPCPA** (Optical Parametric Chirped Pulse Amplification) technology
- ▶ Patented front-end design (patents no. EP2827461 and EP2924500)
- ▶ Up to **1 J** pulse energy at **5 Hz** repetition rate
- ▶ From **Single Shot** to **100 Hz** pulse repetition rate
- ▶ Down to **10 fs** pulse duration
- ▶ Up to **50 mJ** pulse energy at **100 Hz** repetition rate
 - Excellent pulse energy stability: $\leq 1\%$ RMS
 - Excellent long-term average power stability: $\leq 1.5\%$ RMS over **8-hour** period
- ▶ Perfectly synchronized fs and ps output option available
- ▶ Hands free wavelength tuning
- ▶ High contrast pulses without any additional improvement equipment

APPLICATIONS

- ▶ Broadband CARS and SFG
- ▶ Femtosecond pump-probe spectroscopy
- ▶ Nonlinear spectroscopy
- ▶ High harmonic generation
- ▶ Wake field particle acceleration
- ▶ X-ray generation

Multiple stages of NOPCPA (Non-collinear Optical Parametric Chirped Pulse Amplifiers) are used to amplify the stretched pulse from the Stretcher up to 1 J.

Finally, amplified pulses are compressed back down to fs duration in the Pulse Compressor. Bulk glass compressor (combined together with chirped mirror) or traditional diffraction grating compressor can be used depending on pulse duration required and output energy level.

The built-in Output Diagnostics stage ensures reliable, turn-key operation by monitoring critical parameters such as energy, duration, and beam profile.

SPECIFICATIONS

Model	FT310	FT10010	FF50100-F10	FF8005
MAIN SPECIFICATIONS ¹⁾				
Output energy ²⁾				
Signal	3 mJ	100 mJ	50 mJ	800 mJ
SH output ³⁾	0.6 mJ	3.5 mJ ⁴⁾	3.5 mJ ⁴⁾	3.5 mJ ⁴⁾
TH output ³⁾	150 μ J	1.2 mJ ⁴⁾	1.2 mJ ⁴⁾	1.2 mJ ⁴⁾
FH output ³⁾	30 μ J	300 μ J ⁴⁾	300 μ J ⁴⁾	300 μ J ⁴⁾
Pulse repetition rate	10 Hz	10 Hz	100 Hz	5 Hz
Wavelength tuning range				
Signal	750 – 960 nm	750 – 960 nm	840 nm	840 nm
SH output ³⁾	375 – 480 nm	375 – 480 nm	420 nm	420 nm
TH output ³⁾	250 – 320 nm	250 – 320 nm	280 nm	280 nm
FH output ³⁾	210 – 230 nm	210 – 230 nm	210 nm	210 nm
Scanning steps				
Signal	5 nm	5 nm	–	–
SH output ³⁾	5 nm	5 nm	–	–
TH output ³⁾	3 nm	3 nm	–	–
FH output ³⁾	1 nm	1 nm	–	–
Pulse duration ^{5) 6)}	40 \pm 20 fs	40 \pm 20 fs	\leq 10 fs	40 \pm 20 fs
Pulse energy stability ⁷⁾	\leq 1.5 %	\leq 1.5 %	\leq 1 %	\leq 1.5 %
Long-term power drift ⁸⁾	\pm 1.5 %	\pm 1.5 %	\pm 1.5 %	\pm 1.5 %
Beam spatial profile	Super-Gaussian ⁹⁾	Super-Gaussian ⁹⁾	Super-Gaussian ⁹⁾	Super-Gaussian ⁹⁾
Beam diameter ¹⁰⁾	\sim 5 mm	\sim 30 mm	\sim 80 mm	\sim 70 mm
Beam pointing stability ¹¹⁾	\leq 20 μ rad	\leq 20 μ rad	\leq 20 μ rad	\leq 20 μ rad
Temporal contrast ¹²⁾				
APFC (within \pm 50 ps)	$>$ 10 ¹⁰ : 1	$>$ 10 ¹⁰ : 1	$>$ 10 ¹⁰ : 1	$>$ 10 ¹⁰ : 1
Pre-pulse (50 – 10 ps)	$>$ 10 ⁸ : 1	$>$ 10 ⁸ : 1	$>$ 10 ⁸ : 1	$>$ 10 ⁸ : 1
Pre-pulse (10 – 1 ps)	$>$ 10 ⁶ : 1	$>$ 10 ⁶ : 1	$>$ 10 ⁶ : 1	$>$ 10 ⁶ : 1
Post-pulse (beyond 20 ps)	$>$ 10 ⁶ : 1	$>$ 10 ⁶ : 1	$>$ 10 ⁶ : 1	$>$ 10 ⁶ : 1
Optical pulse jitter ¹³⁾				
Trig out	\leq 100 ps	\leq 100 ps	\leq 100 ps	\leq 100 ps
Pre-Trig out	\leq 50 ps	\leq 50 ps	\leq 50 ps	\leq 50 ps
With –PLL option	\leq 2 ps	\leq 2 ps	\leq 2 ps	\leq 2 ps
Polarization	Linear	Linear	Linear	Linear
PHYSICAL CHARACTERISTICS ¹⁴⁾				
Laser head size (W×L×H mm)	900 × 1500 × 300	1200 × 2000 × 300	1200 × 3600 × 500	1500 × 2000 × 500, 2 pc. 1200 × 2500 × 500
Power supply size (W×L×H mm)	553 × 600 × 850	553 × 600 × 1200	553 × 600 × 1020 553 × 600 × 500	553 × 600 × 1800, 2 pc. 553 × 600 × 500
Umbilical length ¹⁵⁾	5 m	5 m	2.5 m	5 m

Model	FT310	FT10010	FF50100-F10	FF8005
OPERATING REQUIREMENTS ¹⁶⁾				
Electrical power	200 – 240 V AC, single-phase, 47 – 63 Hz	200 – 240 V AC, single-phase, 47 – 63 Hz	208, 380 or 400 V AC, three-phase, 50/60 Hz ¹⁷⁾	208, 380 or 400 V AC, three-phase, 50/60 Hz ¹⁷⁾
Power consumption ¹⁸⁾	≤ 1 kVA	≤ 3.5 kVA	≤ 6 kVA	≤ 11 kVA
Water supply	≤ 3 l/min, 2 Bar, max 20 °C	≤ 6 l/min, 2 Bar, max 20 °C	≤ 10 l/min, 2 Bar, max 20 °C	≤ 14 l/min, 2 Bar, max 15 °C
Operating ambient temperature	22 ± 2 °C	22 ± 2 °C	22 ± 2 °C	22 ± 2 °C
Storage ambient temperature	15 – 35 °C	15 – 35 °C	15 – 35 °C	15 – 35 °C
Relative humidity (non-condensing)	≤ 80 %	≤ 80 %	≤ 80 %	≤ 80 %
Cleanness of the room	ISO Class 7	ISO Class 7	ISO Class 7	ISO Class 7

¹⁾ Due to continuous improvement, all specifications are subject to change without notice. The parameters marked 'typical' are indications of typical performance and will vary with each unit we manufacture. Presented parameters can be customized to meet customer's requirements.

²⁾ Maximum pulse energy specified at 840 nm, SH output at 420 nm, TH output at 280 nm and FH output at 210 nm.

³⁾ Harmonic outputs are optional. Specifications valid with respective harmonic module purchased. Outputs are not simultaneous. Maximum harmonic energy depends on OPCPA signal beam profile and pulse duration.

⁴⁾ Maximum pump energy for harmonics is limited to 10 mJ @ 840 nm.

⁵⁾ Standard pulse duration changes though the wavelength range – shortest pulse duration is achieved ~840 nm spectral range.

⁶⁾ Separate 'F10' option can be ordered to reduce pulse duration to ≤ 10 fs. Wavelength tunability not available with 'F10' option.

⁷⁾ Under stable environmental conditions, normalized to average pulse energy (RMS, averaged from 60 s).

⁸⁾ Measured over 8 hours period after 30 min warm-up when ambient temperature variation is less than ±2 °C.

⁹⁾ Super-Gaussian spatial mode of 6-11th order in near field.

¹⁰⁾ Beam diameter is measured at signal output at 1/e² level for Gaussian beams and FWHM level for Super-Gaussian beams.

¹¹⁾ Beam pointing stability is evaluated as movement of the beam centroid in the focal plane of a focusing element (RMS, averaged from 60 s).

¹²⁾ Pulse contrast is only limited by amplified parametric fluorescence (APFC) in the temporal range of ~90 ps which covers OPCPA pump pulse duration. APFC contrast depends on OPCPA saturation level. Our OPCPA systems are ASE-free and pulse contrast value in nanosecond range is limited only by measurement device capabilities (third-order autocorrelator). There are no pre-pulses generated in the system and post-pulses are eliminated by using wedged transmission optics.

¹³⁾ Optical pulse jitter with respect to electrical outputs:

- Trig out > 3.5 V @ 50 Ω
- Pre-Trig out > 1 V @ 50 Ω
- PLL option > 1 V @ 50 Ω

¹⁴⁾ System sizes are preliminary and depend on customer lab layout and additional options purchased.

¹⁵⁾ Longer umbilical with up to 10 m for flash lamp pumped and up to 5 m for diode pumped systems available upon request.

¹⁶⁾ The laser and auxiliary units must be settled in such a place void of dust and aerosols. It is advisable to operate the laser in air conditioned room, provided that the laser is placed at a distance from air conditioning outlets. The laser should be positioned on a solid worktable. Access from one side should be ensured.

¹⁷⁾ Voltage fluctuations allowed are +10 % / -15 % from nominal value.

¹⁸⁾ Required current rating can be calculated by dividing power rating by mains voltage. Power rating is given in apparent power (kVA) for systems with flash lamp power supplies and in real power (kW) for systems without flash lamp power supplies where reactive power is neglectable.



OPTIONS

Option	Description	Comment
-F10	Short Pulse option reduces output pulse duration to ≤ 10 fs	Wavelength tunability not available with 'F10' option
-CEP	CEP stabilization to ≤ 400 mrad	Passive and active CEP stabilization
-DM	'Deformable Mirror' option for Strehl ration improvement to > 0.9	
-SH/TH/FH	Second, third and fourth harmonic outputs	Typical conversion efficiency from signal is $\sim 35\%$, $\sim 12\%$ and $\sim 3\%$ respectively and depends on beam profile and pulse duration of the system. Harmonic outputs are not simultaneous with signal output
-ps out	Additional narrow spectra ps output that is optically synchronized to main system output	Can be simultaneous and non-simultaneous to the main system output. Offers full optical synchronization to fs pulses
-AW	Air-Water cooling	No external water required. Heat dissipation equals total power consumption

PERFORMANCE

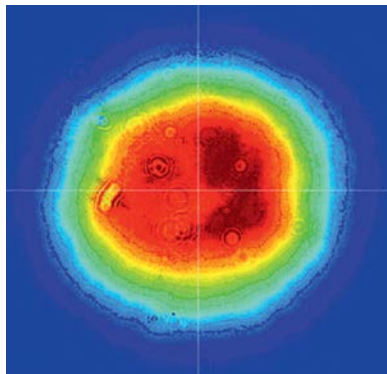

Fig 1. Typical UltraFlux FT310 near field beam profile

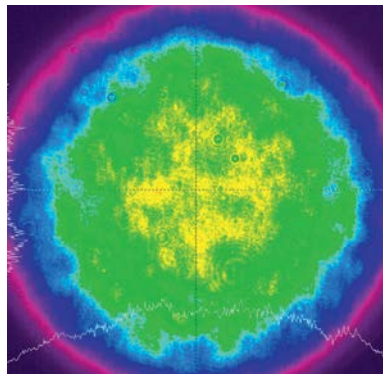

Fig 2. Typical UltraFlux FT10010 and FF50100-F10 near field beam profile

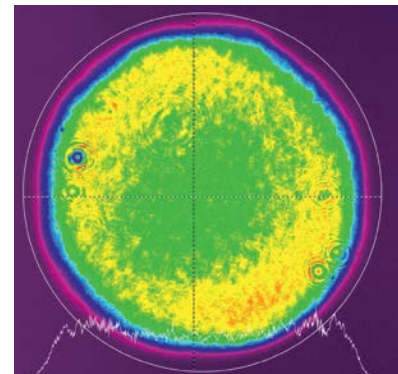

Fig 3. Typical UltraFlux FF8005 near field beam profile

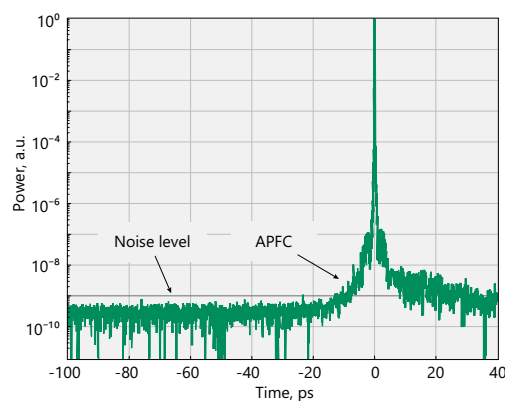

Fig 4. Typical temporal contrast of UltraFlux FF10010 system

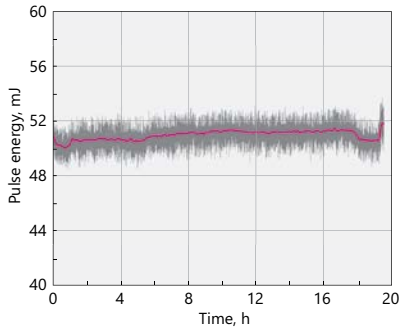

Fig 5. Typical long-term power stability of UltraFlux FF5010-F10 system at 840 nm

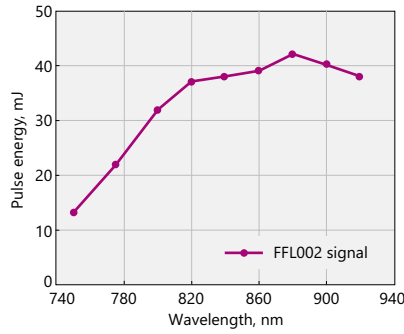

Fig 6. Typical tuning curve of UltraFlux FT4010 laser system

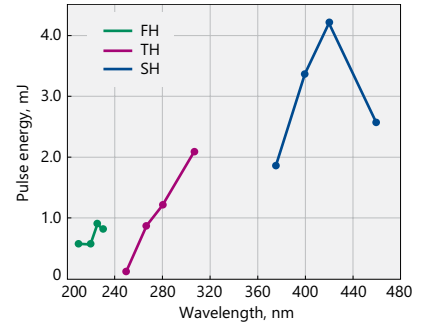

Fig 7. Typical energies of UltraFlux FT4010 second, third and fourth harmonic outputs

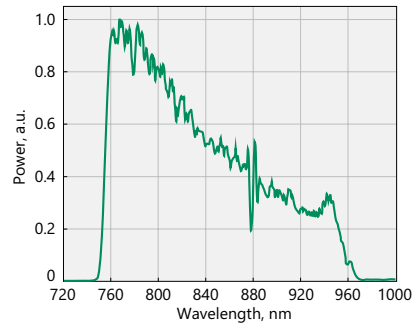

Fig 8. Typical output spectra of UltraFlux FF5010-F10 system

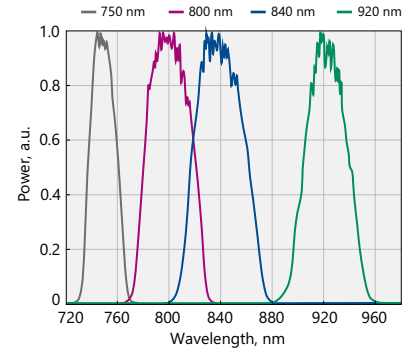

Fig 9. Typical output spectra of UltraFlux FF5010 system at different wavelengths

OUTLINE DRAWINGS



Fig 10. Typical external view of UltraFlux FF5010-F10 system (actual design might vary)

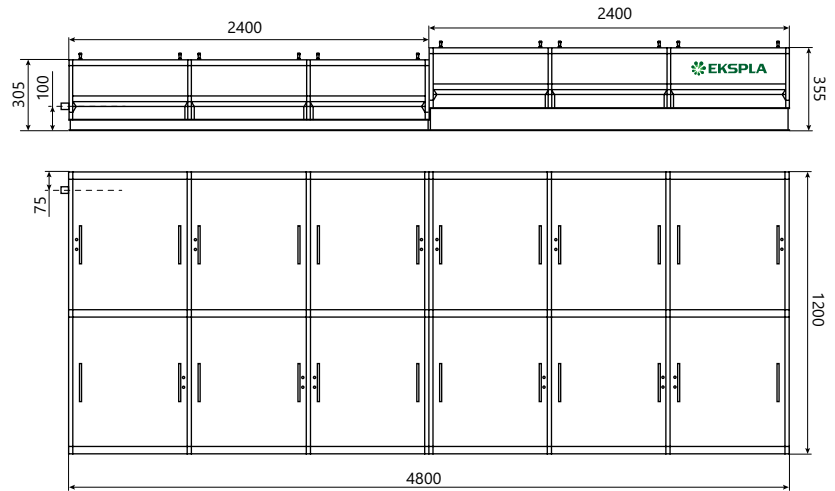

Fig 11. Typical UltraFlux FF5010-F10 laser system external dimensions

POWER SUPPLY

Cabinet	Usable height	Height H, mm	Width W, mm	Depth D, mm
MR-9	9 U	455.5 (519 ¹⁾)	553	600
MR-12	12 U	589 (653 ¹⁾)	553	600
MR-16	16 U	768 (832 ¹⁾)	553	600
MR-20	20 U	889 (952 ¹⁾)	553	600
MR-25	25 U	1167 (1231 ¹⁾)	553	600

¹⁾ Full height with wheels.

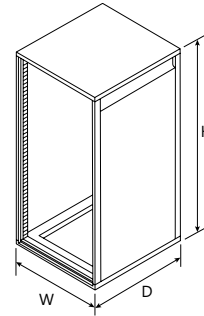

Fig 12. Typical UltraFlux laser system power supply dimensions (MR rack used depends on the laser model)

ORDERING INFORMATION

Note: Laser must be connected to the mains electricity all the time. If there will be no mains electricity for longer than 1 hour then laser (system) needs warm up for a few hours before switching on.

UltraFlux (1) (2)(3)-(4)

Fixed or tunable wavelength:
 FF → fixed wavelength
 FT → tunable wavelength

Energy level:
 3 → 3 mJ
 50 → 50 mJ
 100 → 100 mJ
 800 → 800 mJ

Any additional options:
 See 'Options' table

Pulse repetition rate:
 5 → 5 kHz
 10 → 10 Hz
 100 → 100 Hz

Multi TW Few cycle OPCPA systems



Unique OPCPA based laser system, providing ~15 terawatts of output power at 1 kHz repetition rate and an 8 fs pulse duration. Has been designed and built for ELI-ALPS facilities located in Szeged, Hungary

Since their invention, lasers have been extremely effective to improve our understanding of the molecular and atomic structure of matter and the associated dynamical events. However, laser pulse energy was not enough to probe deeper – into nucleons and their components the quarks or to dissociate the vacuum. A new type of large-scale laser infrastructure specifically designed to produce the highest peak power and focused intensity was established by the European Community: the Extreme Light Infrastructure (ELI). ELI was designed to be the first exawatt class laser facility, equivalent to 1000 times the National Ignition Facility (NIF) power. Producing kJ of power over 10 fs, ELI will afford wide benefits to society ranging from improvement of oncology treatment, medical and biomedical imaging, fast electronics and our understanding of aging nuclear reactor materials to development of new methods of nuclear waste processing.

The facility will be based on four sites. Three of them are implemented in the Czech Republic, Hungary and Romania.

ELI-ALPS based in Szeged (Hungary), one of the three pillars of the Extreme Light Infrastructure, will further deepen knowledge in fundamental physics by providing high repetition rate intense light pulses on the attosecond timescale. Current technological limitations will be overcome by use of novel concepts. The main technological backbone of ELI-ALPS will be optical parametric chirped-pulse amplification (OPCPA) of few-cycle to sub-cycle laser pulses.

Pumped by dedicated all-solid-state short-pulse (ps-scale) sources and their (low-order) harmonics, this approach will be competitive with conventional (Ti:Sapphire laser based) femtosecond technology in terms of pumping efficiency and will dramatically outperform previous technologies in terms of average

UltraFlux Custom

FEATURES

- ▶ Driven by low maintenance cost diode-pumped and industry-tested Yb:KGW and Nd:YAG lasers running at 1 kHz repetition rate
- ▶ > **120 W** average power combined with > **15 TW** peak power, along with sub-250 mrad carrier-envelope phase stability (CEP) and **sub-8 fs** pulse duration at a center wavelength of **900 nm**
- ▶ Amplified Spontaneous Emission (ASE) – free, passively CEP stabilized pulses have excellent stability of output parameters over 24 hours of continuous operation
- ▶ Despite its unique set of specifications, it is still a table-top system
- ▶ A sophisticated self-diagnostic system allows hands-free operation and output specification stability all day long without operator intervention

APPLICATIONS

- ▶ Fundamental frontier particle physics research
- ▶ Nuclear Photonics
- ▶ High harmonic generation
- ▶ Attosecond pulse generation
- ▶ Wake field particle acceleration
- ▶ X-ray generation

power, contrast, bandwidth, and – as a consequence – degree of control of the generated radiation. The ELI-ALPS laser architecture will consist of three main laser beamlines, operating at different regimes of repetition rates and peak powers: High Repetition Rate (HR): 100 kHz, > 5 mJ, ≤ 6 fs, Single Cycle (SYLOS): 1 kHz, > 120 mJ, ≤ 8 fs, High Field (HF): 10 Hz, 34 J, ≤ 17 fs.

The Single Cycle Laser SYLOS laser system is based on OPCPA (Optical Parametric Chirped-Pulse Amplification) technology, developed at Vilnius university.

Unlike other TW-level systems available in the market that operate in a single-shot or low repetition rate mode, SYLOS 3 will run at a 1 kHz repetition rate. With this novel approach, researchers will be able to collect significantly more data and transition from fundamental to

applied science experiments. Such systems enable the development of promising future technologies, such as laser-based particle accelerators.

ELI-ALPS laser system is employed in a wide range of experiments, such as generating coherent X-ray radiation through gas, electron acceleration and surface higher-order harmonic generation. The generation of isolated attosecond pulses for attosecond metrology is another important application. These kinds of experiments demand high stability of operation with high uptime, so the stability and precision of the whole system are one of researchers top priorities.

Due to the exceptionally large XUV/X-ray energy, this system opens the door to nonlinear XUV and X-ray science, as well as 4D imaging and industrial, biological, and medical applications.

To ensure reliability and cutting-edge parameters, the system has been built from scratch by employing industry-tested technologies and components. All design and manufacturing activities have been carried out in facilities in Vilnius. Thus, despite its complexity, the system ensures exceptional stability and reliability. SYLOS 3 delivers approximately 120 mJ pulses with a CEP (Carrier-Envelope Phase) stability of less than 250 mrad and pulse energy stability of less than 1%.

SYLOS series laser systems are outstanding outcome of close cooperation between researchers and engineers. As result the Szeged facility stands out among institutes producing the highest intensity laser pulses in the world at a 1 kHz pulse repetition rate.

SPECIFICATIONS

Model	FF401k-F8-CEP	FF1201k-F8-CEP
MAIN SPECIFICATIONS ¹⁾		
Output energy	40 mJ	120 mJ
Peak pulse power	> 5 TW	> 15 TW
Pulse repetition rate	1 kHz	1 kHz
Wavelength ²⁾	900 nm	900 nm
Pulse duration	≤ 8 fs (≤ 3 cycles)	≤ 8 fs (≤ 3 cycles)
Pulse energy stability ³⁾	≤ 1 %	≤ 1 %
Long-term power drift ⁴⁾	± 1.5 %	± 1.5 %
CEP stability	≤ 250 mrad	≤ 250 mrad
Beam spatial profile	Super-Gaussian ⁵⁾	Super-Gaussian ⁵⁾
Beam diameter	~ 50 mm	~ 100 mm
Beam pointing stability ⁶⁾	≤ 20 μrad	≤ 20 μrad
Strehl ratio ⁷⁾	> 0.7	> 0.7
Temporal contrast ⁸⁾		
APFC (within ± 50 ps)	10 ¹⁰ : 1	10 ¹⁰ : 1
Pre-pulse (≤ 50 ps)	10 ¹⁰ : 1	10 ¹⁰ : 1
Post-Pulse (>50 ps)	10 ⁸ : 1	10 ⁸ : 1
PHYSICAL CHARACTERISTICS ⁹⁾		
Laser head size (W×L×H mm)	9000 × 5000 × 1200	9000 × 9000 × 1200
Umbilical length	up to 10 m	up to 5 m

Model	FF401k-F8-CEP	FF1201k-F8-CEP
OPERATING REQUIREMENTS ¹⁰⁾		
Electrical power	208, 380 or 400 V AC, three-phase, 50/60 Hz ¹¹⁾	208, 380 or 400 V AC, three-phase, 50/60 Hz ¹¹⁾
Power consumption ¹²⁾	≤ 40 kVA	≤ 60 kVA
Water supply	≤ 30 l/min, 2 Bar, max 15 °C	≤ 40 l/min, 2 Bar, max 15 °C
Operating ambient temperature	22 ± 2 °C	22 ± 2 °C
Storage ambient temperature	15 – 35 °C	15 – 35 °C
Relative humidity (non-condensing)	≤ 80 %	≤ 80 %
Cleanness of the room	ISO Class 7	ISO Class 7

¹⁾ Due to continuous improvement, all specifications are subject to change without notice. The parameters marked 'typical' are indications of typical performance and will vary with each unit we manufacture. Presented parameters can be customized to meet customer's requirements.

²⁾ Central wavelength is calculated as the power-weighted mean frequency from measured spectrum in frequency domain.

³⁾ Under stable environmental conditions, normalized to average pulse energy (RMS, averaged from 30 s).

⁴⁾ Measured over 8 hours period after 30 min warm-up when ambient temperature variation is less than ±2 °C.

⁵⁾ Super-Gaussian spatial mode of 6-11th order in near field.

⁶⁾ Beam pointing stability is evaluated as movement of the beam centroid in the focal plane of a focusing element (RMS, averaged from 30 s).

⁷⁾ Strehl ratio of > 0.7 is achieved with deformable mirror option.

⁸⁾ Pulse contrast is only limited by amplified parametric fluorescence (APFC) in the temporal range of ~90 ps which covers OPCPA pump pulse duration and is better than 10⁶:1. APFC contrast depends on OPCPA saturation level. Our OPCPA systems are ASE-free and pulse contrast value in nanosecond range is limited only by measurement device capabilities (third-order autocorrelator). There are no pre-pulses generated in the system and post-pulses are eliminated by using wedged transmission optics.

⁹⁾ System sizes are preliminary and depend on customer lab layout and additional options purchased.

¹⁰⁾ The laser and auxiliary units must be settled in such a place void of dust and aerosols. It is advisable to operate the laser in air conditioned room, provided that the laser is placed at a distance from air conditioning outlets. The laser should be positioned on a solid worktable. Access from one side should be ensured.

¹¹⁾ Voltage fluctuations allowed are +10 % / -15 % from nominal value.

¹²⁾ Required current rating can be calculated by dividing power rating by mains voltage. Power rating is given in apparent power (kVA) for systems with flash lamp power supplies and in real power (kW) for systems without flash lamp power supplies where reactive power is neglectable.



OPTIONS

Option	Description	Comment
-F8	Short Pulse option reduces output pulse duration to ≤ 8 fs	Wavelength tunability not available with 'F8' option
-CEP	CEP stabilization to ≤ 250 mrad	Passive and active CEP stabilization
-DM	'Deformable Mirror' option for Strehl ration improvement to > 0.7	
-ps out	Additional narrow spectra ps output that is optically synchronized to main system output	Can be simultaneous and non-simultaneous to the main system output

PERFORMANCE

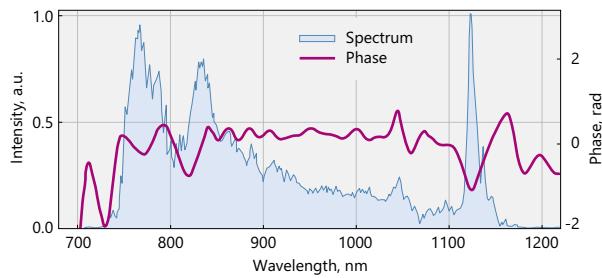

Fig 1. Typical output spectra and spectral phase of UltraFlux FF401k-F8-CEP-DM system

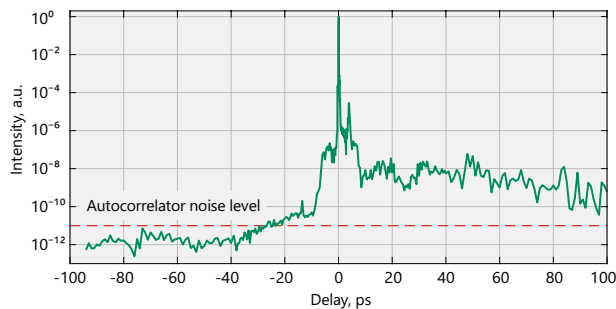

Fig 2. Typical temporal contrast of UltraFlux FF401k-F8-CEP-DM system

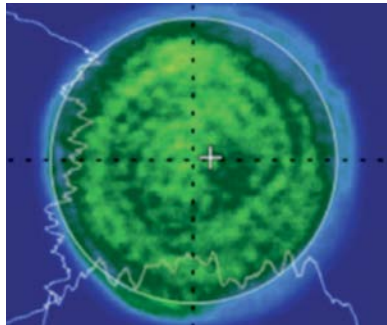

Fig 4. Typical UltraFlux FF401k-F8-CEP-DM near field beam profile

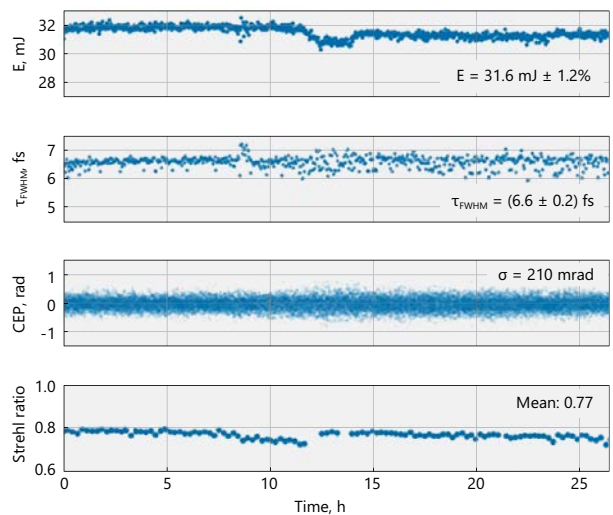

Fig 3. Typical long-term energy, pulse duration, CEP and Strehl ratio stability of UltraFlux FF401k-F8-CEP-DM system



Fig 5. Typical external view of UltraFlux FF401k-F8-CEP-DM system (ELI-ALPS, SYLOS2A system)

ORDERING INFORMATION

UltraFlux FF(1)(2)-(3)

Energy level:
40 → 50 mJ
100 → 100 mJ

Pulse repetition rate:
100 → 100 Hz
1k → 1 kHz

Additional options:

- F8 → output pulse duration to ≤ 8 fs
- CEP → CEP stabilization to ≤ 250 mrad
- DM → Deformable Mirror' option for Strehl ration improvement to > 0.7
- ps out → Additional ps output that is optically synchronized to main system output.

High Energy Flash Lamp Pumped Picosecond Amplifiers

PicoFlux HE SERIES



APPLICATIONS

- ▶ Time resolved spectroscopy
- ▶ SFG/SHG spectroscopy
- ▶ Nonlinear spectroscopy
- ▶ OPCPA pumping
- ▶ OPG/OPA pumping
- ▶ Remote laser sensing
- ▶ Satellite ranging
- ▶ Other spectroscopic and nonlinear optics applications...

FEATURES

- ▶ **Flash lamp pumped picosecond amplifiers**
- ▶ Pulse energies up to **2.2 J**
- ▶ **20 – 300 ps** pulse duration
- ▶ **10 Hz** pulse repetition rate
- ▶ Diode pumped regenerative amplifier
- ▶ Internal or external seeding source
- ▶ Advanced beam shaping for high pulse energy
- ▶ Thermally induced birefringence compensated design
- ▶ Less than **10 ps RMS** jitter synchronization pulses for streak camera triggering
- ▶ Control through USB and LAN interfaces with supplied Windows control software (RS232 optional)
- ▶ Vacuum image relay system
- ▶ Optional temperature stabilized second, third and fourth harmonic generators
- ▶ Optional extremely precise synchronization to external RF signal with PLL option
- ▶ Optional Gaussian like spatial beam profile with Gaussian fit > 85% in near field
- ▶ Optional reduced pulse duration to 20 ps

High energy PicoFlux series amplifiers are designed to produce high energy picosecond pulses at 1064 nm. High pulse energy, excellent pulse-to-pulse energy stability, superior beam quality makes these amplifiers well suited for applications like OPCPA pumping, non-linear optics and others.

Regenerative amplifier / Power amplifier design

PicoFlux series amplifiers are designed to be seeded by external seeding source. Diode pumped regenerative amplifier ensures amplification of seed signal to stable mJ level pulse

for amplification in linear amplifiers. Advanced beam shaping ensures smooth, without hot spots beam spatial profile at the laser output. Low light depolarization level allows high efficiency generation of up to 4th harmonic with optional build-in harmonic generators. Alternatively EKSPLA can offer an internal seeder meeting customer's requirements.

Build-in harmonic generators

Angle-tuned non-linear crystals harmonic generators mounted in temperature stabilized heaters are

used for second, third and fourth harmonic generation. Harmonic separation system is designed to ensure high spectral purity of radiation and direct it to the output ports.

Simple and convenient laser control

For customer convenience the amplifier can be controlled through USB and LAN interfaces (RS232 as optional). The amplifier can be controlled from personal computer with supplied software for Windows operating system.

SPECIFICATIONS

Model	P30010	P60010	P1k10	P2k10
MAIN SPECIFICATIONS ¹⁾				
Output energy				
Fundamental	300 mJ	600 mJ	1 000 mJ	2 200 mJ ^{2) 3)}
SH output ^{4) 5)}	200 mJ	400 mJ	650 mJ	1 400 mJ
TH output ⁴⁾	90 mJ	180 mJ	300 mJ	660 mJ
FH output ⁴⁾	30 mJ	60 mJ	100 mJ	220 mJ
Pulse repetition rate	10 Hz	10 Hz	10 Hz	10 Hz
Pulse duration ⁶⁾	90 ± 10 ps	90 ± 10 ps	90 ± 10 ps	90 ± 10 ps
Pulse energy stability ⁷⁾				
Fundamental	≤ 0.6 %	≤ 0.6 %	≤ 0.6 %	≤ 0.6 %
SH output ⁴⁾	≤ 0.8 %	≤ 0.8 %	≤ 0.8 %	≤ 0.8 %
TH output ⁴⁾	≤ 2 %	≤ 2 %	≤ 2 %	≤ 2 %
FH output ⁴⁾	≤ 3 %	≤ 3 %	≤ 3 %	≤ 3 %
Long-term power drift ⁸⁾	± 2 %	± 2 %	± 2 %	± 2 %
Beam spatial profile	Super-Gaussian ⁹⁾	Super-Gaussian ⁹⁾	Super-Gaussian ⁹⁾	Super-Gaussian ⁹⁾
Beam diameter ¹⁰⁾	9 mm	~11 mm	~17 mm	~23 mm
Beam pointing stability ¹¹⁾	≤ 30 µrad	≤ 30 µrad	≤ 30 µrad	≤ 30 µrad
Beam divergence	≤ 0.5 mrad	≤ 0.5 mrad	≤ 0.5 mrad	≤ 0.5 mrad
Pre-pulse contrast ¹²⁾	> 200:1	> 200:1	> 200:1	> 200:1
Optical pulse jitter ¹³⁾				
Trig out	≤ 100 ps	≤ 100 ps	≤ 100 ps	≤ 100 ps
Pre-Trig out	≤ 50 ps	≤ 50 ps	≤ 50 ps	≤ 50 ps
With -PLL option	≤ 2 ps	≤ 2 ps	≤ 2 ps	≤ 2 ps
Polarization	Linear	Linear	Linear	Linear
PHYSICAL CHARACTERISTICS ¹⁴⁾				
Laser head size (W×L×H mm)	600 × 1200 × 300	600 × 1500 × 300	600 × 1800 × 300	900 × 1800 × 300
Power supply size (W×L×H mm)	553 × 600 × 650	553 × 600 × 830	553 × 600 × 1230	553 × 600 × 1230
Umbilical length ¹⁵⁾	2.5 m	2.5 m	2.5 m	2.5 m
OPERATING REQUIREMENTS ¹⁶⁾				
Electrical power	200 – 240 V AC, single-phase, 47 – 63 Hz	200 – 240 V AC, single-phase, 47 – 63 Hz	208, 380 or 400 V AC, three-phase, 50/60 Hz ¹⁷⁾	208, 380 or 400 V AC, three-phase, 50/60 Hz ¹⁷⁾
Power consumption ¹⁸⁾	≤ 2 kVA	≤ 2.5 kVA	≤ 4.5 kVA	≤ 7 kVA
Water supply	≤ 3 l/min, 2 Bar, max 20 °C	≤ 6 l/min, 2 Bar, max 20 °C	≤ 12 l/min, 2 Bar, max 20 °C	≤ 14 l/min, 2 Bar, max 15 °C
Operating ambient temperature	22 ± 2 °C	22 ± 2 °C	22 ± 2 °C	22 ± 2 °C
Storage ambient temperature	15 – 35 °C	15 – 35 °C	15 – 35 °C	15 – 35 °C
Relative humidity (non-condensing)	≤ 80 %	≤ 80 %	≤ 80 %	≤ 80 %
Cleanness of the room	ISO Class 7	ISO Class 7	ISO Class 7	ISO Class 7

¹⁾ Due to continuous improvement, all specifications are subject to change without notice. The parameters marked 'typical' are indications of typical performance and will vary with each unit we manufacture. Presented parameters can be customized to meet customer's requirements. All parameters measured at 1064 nm if not stated otherwise.

²⁾ 2 200 mJ energy is achieved with Super-Gaussian spatial beam profile of 11th or higher order (with steep edges). If lower order Super-Gaussian is required maximum pulse energy will be limited to 2 000 mJ.

³⁾ 2 500 mJ output energy is available upon request with longer pulse duration.

⁴⁾ Harmonic outputs are optional. Specifications valid with respective harmonic module purchased. Outputs are not simultaneous.

⁵⁾ Second harmonic specification is valid when only SH option is ordered. If TH/FH options are ordered second harmonic efficiency is reduced to ~50 %.

⁶⁾ Standard pulse duration is 90 ps. Other pulse durations can be ordered within range of 20 ps – 300 ps. Shortening the pulse duration below 90 ps will reduce the output energy proportionally.

⁷⁾ Under stable environmental conditions, normalized to average pulse energy (RMS, averaged from 60 s).

⁸⁾ Measured over 8 hours period after 30 min warm-up when ambient temperature variation is less than ±2 °C.

⁹⁾ Super-Gaussian spatial mode of 6-11th order in near field.



- ¹⁰⁾ Beam diameter is measured at signal output at $1/e^2$ level for Gaussian beams and FWHM level for Super-Gaussian beams.
- ¹¹⁾ Beam pointing stability is evaluated as movement of the beam centroid in the focal plane of a focusing element (RMS, averaged from 60 s).
- ¹²⁾ 1000:1 contrast available upon request.
- ¹³⁾ Optical pulse jitter with respect to electrical outputs:
 - Trig out > 3.5 V @ 50 Ω
 - Pre-Trig out > 1 V @ 50 Ω
 - PLL option > 1 V @ 50 Ω
- ¹⁴⁾ System sizes are preliminary and depend on customer lab layout and additional options purchased.
- ¹⁵⁾ Longer umbilical with up to 10 m available upon request.
- ¹⁶⁾ The laser and auxiliary units must be settled in such a place void of dust and aerosols. It is advisable to operate the laser in air conditioned room, provided that the laser is placed at a distance from air conditioning outlets. The laser should be positioned on a solid worktable. Access from one side should be ensured.
- ¹⁷⁾ Voltage fluctuations allowed are +10 % / -15 % from nominal value.
- ¹⁸⁾ Required current rating can be calculated by dividing power rating by mains voltage. Power rating is given in apparent power (kVA) for systems with flash lamp power supplies and in real power (kW) for systems without flash lamp power supplies where reactive power is neglectable.

OPTIONS

Option	Description	Comment
-P20...300	Custom pulse duration between 20 ps and 300 ps	Available with internal and external seeder. Shortening the pulse duration below 90 ps will reduce the output energy proportionally
-G	Gaussian like spatial beam profile	Reduces the output energy of fundamental by ~80 %
-FS	External seeder input via motorized spectral broadening stage	Requires > 1.5 nJ per pulse @ 800 nm, \leq 100 fs
-PLL	Phase Lock Loop option for precise lock to external RF signal	Electrical to optical signal jitter \leq 3 ps
-SH/TH/FH	Second, third and fourth harmonic outputs	Conversion efficiency from fundamental respectively ~50 %, ~30 % and ~10 %. Harmonic outputs not simultaneous with fundamental output
-AW	Water-to-Air cooling	Replaces or supplements Water-to-Water cooling unit. Heat dissipation equals total power consumption

POWER SUPPLY

Cabinet	Usable height	Height H, mm	Width W, mm	Depth D, mm
MR-9	9 U	455.5 (519 ¹⁾)	553	600
MR-12	12 U	589 (653 ¹⁾)	553	600
MR-16	16 U	768 (832 ¹⁾)	553	600
MR-20	20 U	889 (952 ¹⁾)	553	600
MR-25	25 U	1167 (1231 ¹⁾)	553	600

¹⁾ Full height with wheels.

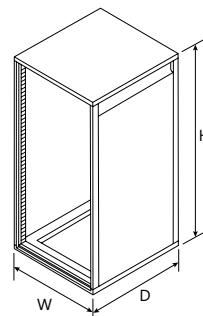

Fig 1. Typical PicoFlux laser system power supply dimensions (MR rack used depends on the laser model)



Fig 2. Integrated multi-channel high energy PicoFlux pump lasers into OPCA

PERFORMANCE

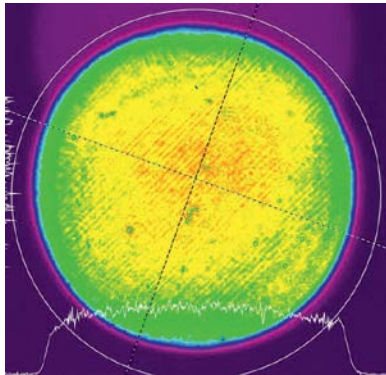

Fig 3. Typical High Energy PicoFlux amplifier system near field beam profile at 1064 nm (imaged from laser output)

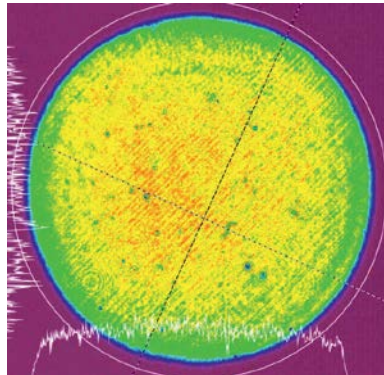

Fig 4. Typical High Energy PicoFlux amplifier system near field beam profile at 532 nm (imaged from SH crystal)

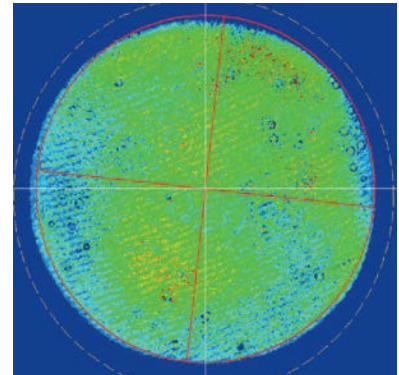

Fig 5. Typical High Energy PicoFlux amplifier system near field beam profile at 355 nm (imaged from TH crystal)

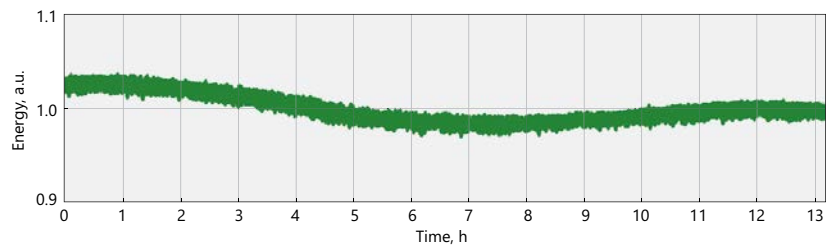

Fig 6. Typical long-term energy stability of High Energy PicoFlux system

OUTLINE DRAWINGS

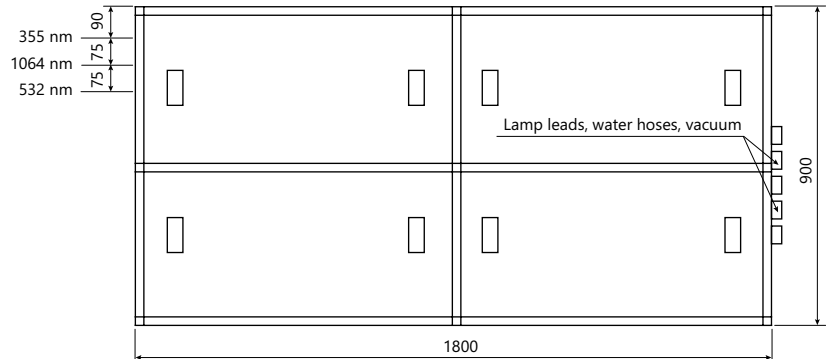

Fig 7. Typical PicoFlux P2k10 laser system external dimensions

ORDERING INFORMATION

Note: Laser must be connected to the mains electricity all the time. If there will be no mains electricity for longer than 1 hour then laser (system) needs warm up for a few hours before switching on.

PicoFlux P(1)(2)-(3)

	Any additional options: See 'Options' table	
Energy level:		Pulse repetition rate:
300 → 300 mJ		SS → Single Shot
600 → 600 mJ		5 → 5 Hz
1k → 1000 mJ		10 → 10 Hz
2k → 2200 mJ		

High Repetition Rate Diode Pumped Picosecond Amplifiers

PicoFlux HP SERIES



APPLICATIONS

- ▶ Time resolved spectroscopy
- ▶ SFG/SHG spectroscopy
- ▶ Nonlinear spectroscopy
- ▶ OPCPA pumping
- ▶ OPG/OPA pumping
- ▶ Remote laser sensing
- ▶ Satellite ranging
- ▶ Other spectroscopic and nonlinear optics applications...

FEATURES

- ▶ Diode pumped picosecond amplifiers
- ▶ Pulse energies up to **150 mJ**
- ▶ **20 – 300 ps** pulse duration
- ▶ High pulse energy up to **2 kHz** pulse repetition rate
- ▶ Diode pumped solid state design
- ▶ Advanced beam shaping for high pulse energy
- ▶ Internal or external seeding source
- ▶ Thermally induced birefringence compensated
- ▶ Low maintenance costs
- ▶ Less than **10 ps RMS** jitter synchronization pulses for streak camera triggering
- ▶ Control through USB and LAN interfaces with supplied Windows control software (RS232 optional)
- ▶ Vacuum image relay system
- ▶ Optional temperature stabilized second, third and fourth harmonic generators
- ▶ Optional extremely precise synchronization to external RF signal with PLL option
- ▶ Optional Gaussian like spatial beam profile with Gaussian fit > 85 % in near field
- ▶ Optional reduced pulse duration to 20 ps

High repetition rate PicoFlux series amplifiers are designed to produce up to 150 mJ picosecond pulses at 1 kHz repetition rate (or 500 mJ at 100 Hz repetition rate). High pulse energy, excellent pulse-to-pulse energy stability, superior beam quality makes these amplifiers well suited for applications like OPCPA pumping, non-linear optics and others.

Regenerative amplifier / Power amplifier design

PicoFlux series amplifiers are designed to be seeded by external seeding source. Diode pumped regenerative amplifier ensures amplification of

seed signal to stable mJ level pulse for amplification in linear amplifiers. Advanced beam shaping ensures smooth, without hot spots beam spatial profile at the laser output. Low light depolarization level allows high efficiency generation of up to 4th harmonic with optional build-in harmonic generators. Alternatively EKSPLA can offer an internal seeder meeting customer's requirements.

Build-in harmonic generators

Angle-tuned LBO and/or BBO crystals mounted in temperature stabilized heaters are used for second, third

and fourth harmonic generation. Harmonic separation system is designed to ensure high spectral purity of radiation and direct it to the output ports.

Simple and convenient laser control

For customer convenience the amplifier can be controlled through USB and LAN interfaces (RS232 as optional). The amplifier can be controlled from personal computer with supplied software for Windows operating system.

SPECIFICATIONS

Model	P500100	P301k	P601k	P1301k
MAIN SPECIFICATIONS ¹⁾				
Output energy				
Fundamental	500 mJ	30 mJ	60 mJ	130 mJ
SH output ^{2) 3)}	300 mJ	20 mJ	40 mJ	85 mJ
TH output ²⁾	200 mJ	10 mJ	20 mJ	50 mJ
FH output ²⁾	50 mJ	3 mJ	6 mJ	15 mJ
Pulse repetition rate	100 Hz	1 kHz	1 kHz	1 kHz
Pulse duration ⁴⁾	90 ± 10 ps	90 ± 10 ps	90 ± 10 ps	90 ± 10 ps
Pulse energy stability ⁵⁾				
Fundamental	≤ 0.5 %	≤ 0.5 %	≤ 0.5 %	≤ 0.5 %
SH output ²⁾	≤ 0.8 %	≤ 0.8 %	≤ 0.8 %	≤ 0.8 %
TH output ²⁾	≤ 2 %	≤ 2 %	≤ 2 %	≤ 2 %
FH output ²⁾	≤ 3 %	≤ 3 %	≤ 3 %	≤ 3 %
Long-term power drift ⁶⁾	± 1.5 %	± 1.5 %	± 1.5 %	± 1.5 %
Beam spatial profile				
Beam diameter ⁸⁾	Super-Gaussian ⁷⁾ ~ 12 mm	Super-Gaussian ⁷⁾ ~ 5 mm	Super-Gaussian ⁷⁾ ~ 7 mm	Super-Gaussian ⁷⁾ ~ 7 mm
Beam pointing stability ⁹⁾	≤ 20 µrad	≤ 20 µrad	≤ 20 µrad	≤ 20 µrad
Beam divergence	≤ 0.5 mrad	≤ 0.5 mrad	≤ 0.5 mrad	≤ 0.5 mrad
Pre-pulse contrast ¹⁰⁾	> 200:1	> 200:1	> 200:1	> 200:1
Optical pulse jitter ¹¹⁾				
Trig out	≤ 100 ps	≤ 100 ps	≤ 100 ps	≤ 100 ps
Pre-Trig out	≤ 50 ps	≤ 50 ps	≤ 50 ps	≤ 50 ps
With -PLL option	≤ 2 ps	≤ 2 ps	≤ 2 ps	≤ 2 ps
Polarization				
	Linear	Linear	Linear	Linear
PHYSICAL CHARACTERISTICS ¹²⁾				
Laser head size (W×L×H mm)	1200 × 2400 × 300	600 × 1500 × 300	900 × 1500 × 300	900 × 1800 × 300
Power supply size (W×L×H mm)	553 × 600 × 832 377 × 1015 × 1080	553 × 600 × 830	553 × 600 × 1230	553 × 600 × 1230
Umbilical length ¹³⁾	2.5 m	2.5 m	2.5 m	2.5 m
OPERATING REQUIREMENTS ¹⁴⁾				
Electrical power	208, 380 or 400 V AC, three-phase, 50/60 Hz ¹⁵⁾	208, 380 or 400 V AC, three-phase, 50/60 Hz ¹⁵⁾	208, 380 or 400 V AC, three-phase, 50/60 Hz ¹⁵⁾	208, 380 or 400 V AC, three-phase, 50/60 Hz ¹⁵⁾
Power consumption ¹⁶⁾	≤ 5 kW	≤ 5 kW	≤ 10 kW	≤ 22 kW
Water supply	≤ 8 l/min, 2 Bar, max 20 °C	≤ 14 l/min, 2 Bar, max 20 °C	≤ 25 l/min, 2 Bar, max 20 °C	≤ 40 l/min, 2 Bar, max 15 °C
Operating ambient temperature	22 ± 2 °C	22 ± 2 °C	22 ± 2 °C	22 ± 2 °C
Storage ambient temperature	15 – 35 °C	15 – 35 °C	15 – 35 °C	15 – 35 °C
Relative humidity (non-condensing)	≤ 80 %	≤ 80 %	≤ 80 %	≤ 80 %
Cleanness of the room	ISO Class 7	ISO Class 7	ISO Class 7	ISO Class 7

¹⁾ Due to continuous improvement, all specifications are subject to change without notice. The parameters marked 'typical' are indications of typical performance and will vary with each unit we manufacture. Presented parameters can be customized to meet customer's requirements. All parameters measured at 1064 nm if not stated otherwise.

²⁾ Harmonic outputs are optional. Specifications valid with respective harmonic module purchased. Outputs are not simultaneous.

³⁾ Second harmonic specification is valid when only SH option is ordered. If TH/FH options are orders second harmonic efficiency is reduced to ~50 %.

⁴⁾ Standard pulse duration is 90 ps. Other pulse durations can be ordered within range of 20 – 300 ps. Shortening the pulse duration below 90 ps will reduce the output energy proportionally.

⁵⁾ Under stable environmental conditions, normalized to average pulse energy (RMS, averaged from 60 s).

⁶⁾ Measured over 8 hours period after 30 min warm-up when ambient temperature variation is less than ±2 °C.

⁷⁾ Super-Gaussian spatial mode of 6-11th order in near field.

⁸⁾ Beam diameter is measured at signal output at 1/e² level for Gaussian beams and FWHM level for Super-Gaussian beams.



- ⁹⁾ Beam pointing stability is evaluated as movement of the beam centroid in the focal plane of a focusing element (RMS, averaged from 60 s).
- ¹⁰⁾ 1000:1 contrast available upon request.
- ¹¹⁾ Optical pulse jitter with respect to electrical outputs:
 - Trig out > 3.5 V @ 50 Ω
 - Pre-Trig out > 1 V @ 50 Ω
 - PLL option > 1 V @ 50 Ω
- ¹²⁾ System sizes are preliminary and depend on customer lab layout and additional options purchased.
- ¹³⁾ Longer umbilical with up to 5 m available upon request.
- ¹⁴⁾ The laser and auxiliary units must be settled in such a place void of dust and aerosols. It is advisable to operate the laser in air conditioned room, provided that the laser is placed at a distance from air conditioning outlets. The laser should be positioned on a solid worktable. Access from one side should be ensured.
- ¹⁵⁾ Voltage fluctuations allowed are +10 % / -15 % from nominal value.
- ¹⁶⁾ Required current rating can be calculated by dividing power rating by mains voltage. Power rating is given in apparent power (kVA) for systems with flash lamp power supplies and in real power (kW) for systems without flash lamp power supplies where reactive power is neglectable.

OPTIONS

Option	Description	Comment
-P20...300	Custom pulse duration between 20 ps and 300 ps	Available with internal and external seeder. Shortening the pulse duration below 90 ps will reduce the output energy proportionally
-50/100	50 Hz or 100 Hz pulse repetition rate	Energy can be increased ~4 times
-2k	2 kHz pulse repetition rate	Reduces the output energy of fundamental by ~50 %
-G	Gaussian like spatial beam profile	Reduces the output energy of fundamental by ~80 %
-FS	External seeder input via motorized spectral broadening stage	Requires > 1.5 nJ per pulse @ 800 nm, 100 fs
-PLL	Phase Lock Loop option for precise lock to external RF signal	Electrical to optical signal jitter ≤ 3 ps
-SH/TH/FH	Second, third and fourth harmonic outputs	Conversion efficiency from fundamental respectively ~50 %, ~30 % and ~10 %. Harmonic outputs not simultaneous with fundamental output
-AW	Water-to-Air cooling	Replaces or supplements Water-to-Water cooling unit. Heat dissipation equals total power consumption

POWER SUPPLY

Cabinet	Usable height	Height H, mm	Width W, mm	Depth D, mm
MR-9	9 U	455.5 (519 ¹⁾)	553	600
MR-12	12 U	589 (653 ¹⁾)	553	600
MR-16	16 U	768 (832 ¹⁾)	553	600
MR-20	20 U	889 (952 ¹⁾)	553	600
MR-25	25 U	1167 (1231 ¹⁾)	553	600

¹⁾ Full height with wheels.

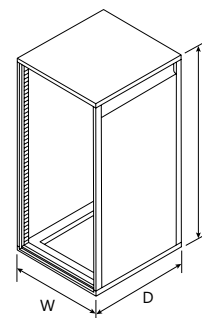

Fig 1. Typical PicoFlux laser system power supply dimensions (MR rack used depends on the laser model)



Fig 2. Typical external view of PicoFlux P1301k laser system (actual design might vary)

PERFORMANCE

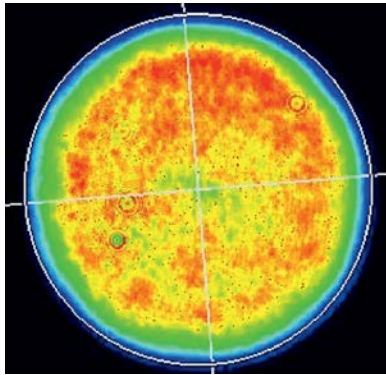

Fig 3. Typical High repetition rate PicoFlux amplifier system near field beam profile at 1064 nm (imaged from laser output)

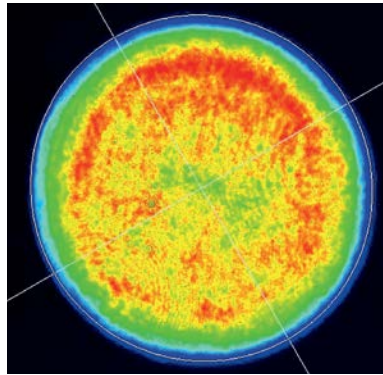

Fig 4. Typical High repetition rate PicoFlux amplifier system near field beam profile at 532 nm (imaged from SH crystal)

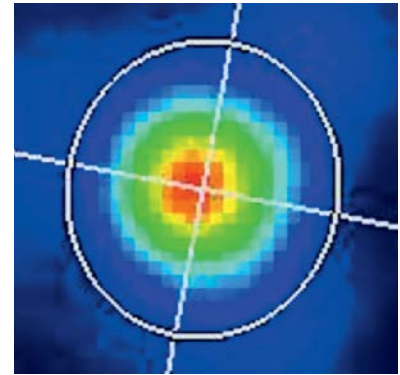

Fig 5. Typical High repetition rate PicoFlux amplifier system far field beam profile at 532 nm

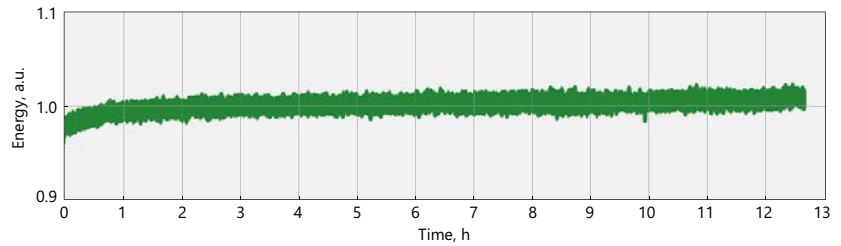

Fig 6. Typical long-term energy stability of High repetition rate PicoFlux amplifier system

OUTLINE DRAWINGS

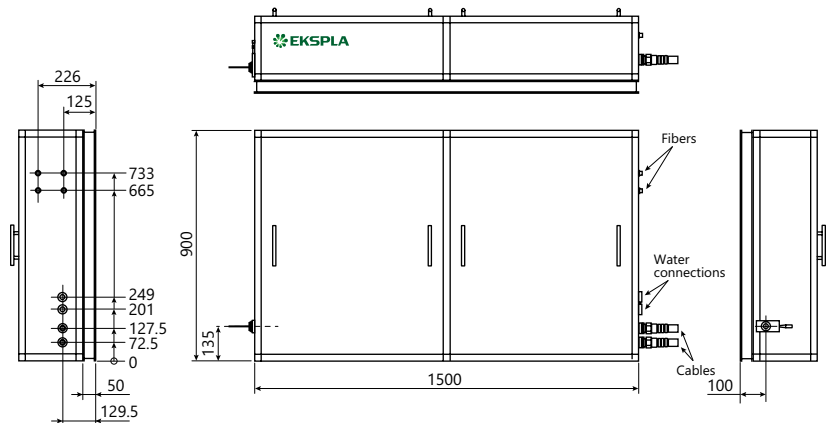

Fig 7. Typical PicoFlux P601k laser system external dimensions

ORDERING INFORMATION

Note: Laser must be connected to the mains electricity all the time. If there will be no mains electricity for longer than 1 hour then laser (system) needs warm up for a few hours before switching on.

PicoFlux P(1)(2)-(3)

	Any additional options: See 'Options' table
Energy level:	Pulse repetition rate:
100 → 10 mJ	50 → 50 Hz
30 → 30 mJ	100 → 100 Hz
60 → 60 mJ	1k → 1 kHz
130 → 130 mJ	2k → 2 kHz
500 → 500 mJ	

Custom Picosecond Amplifiers

PicoFlux Custom



APPLICATIONS

- ▶ Multi-stage OPCPA pumping
- ▶ Non-linear optics
- ▶ Other spectroscopic and nonlinear optics applications...

FEATURES

- ▶ Flash lamp or diode pumped multi-channel PicoFlux systems
- ▶ Each of the channels can be **tailored according to pumping requirements**
- ▶ High energy PicoFlux version with **variable burst**
- ▶ Hybrid PicoFlux with fiber front-end and Yb:YAG amplifiers – **1 ps, 8 mJ output at 10 kHz**
- ▶ **1 – 300 ps** pulse duration
- ▶ From Single Shot to 10 kHz pulse repetition rate
- ▶ Internal or external seeding source
- ▶ Advanced beam shaping for high pulse energy
- ▶ Thermally induced birefringence compensated
- ▶ Low jitter synchronization pulses below 10 ps RMS jitter
- ▶ Vacuum image relay system
- ▶ Optional temperature stabilized second, third and fourth harmonic generators

Multiple Channel PicoFlux series picosecond amplifiers were designed and manufactured for multiple stage OPCPA pumping. Systems can be specially tailored for customer's needs and have up to 8 pumping channels with different wavelength, energy, pulse duration, spatial and temporal profiles, adjustable delay, image translation to customers specified location and various other features. Short pulse duration, excellent pulse-to-pulse stability, superior beam quality makes PicoFlux series picosecond amplifiers well suited for other applications as well.

Regenerative amplifier / Power amplifier design

PicoFlux series amplifiers are designed to be seeded by external seeding source. Diode pumped regenerative amplifier ensures amplification of seed signal to stable mJ level pulse for amplification in linear amplifiers. Advanced beam shaping ensures smooth, without hot spots beam spatial profile at the laser output. Low light depolarization level allows high efficiency generation of up to 4th harmonic with optional build-in harmonic generators.

Alternatively EKSPLA can offer an internal seeder meeting customer's requirements.

Full-fiber front-end

Novel EKSPLA developed fiber front-end opens up new set of unique features for PicoFlux systems like dual wave seeder that also has burst formation functionality due to active fiber loop technology. The front-end also permits to offer powerful, ultrafast and higher frequency Ytterbium amplifiers for wider opportunities in OPCPA pumping and other scientific uses.

SPECIFICATIONS

Model	P2k10-x4	P1301k-x8	P1k100-Burst	P810k-1030
MAIN SPECIFICATIONS ¹⁾				
Output energy				
Fundamental	4 × 2 200 mJ ^{2) 3)}	8 × 130 mJ	1.4 J Burst (4×300 mJ + 4×50 mJ)	8 mJ @ 1030 nm
SH output ^{4) 5)}	4 × 1 400 mJ	8 × 85 mJ	NA	NA
TH output ⁴⁾	4 × 660 mJ	8 × 50 mJ	NA	NA
FH output ⁴⁾	4 × 220 mJ	8 × 15 mJ	NA	NA
Pulse repetition rate	10 Hz	1 kHz	100 Hz	10 kHz
Pulse duration ⁶⁾	90 ± 10 ps	90 ± 10 ps	90 ± 10 ps	1 ± 0.2 ps
Pulse energy stability ⁷⁾				
Fundamental	≤ 0.6 %	≤ 0.5 %	≤ 1 %	≤ 0.5 %
SH output ⁴⁾	≤ 0.8 %	≤ 0.8 %	NA	NA
TH output ⁴⁾	≤ 2 %	≤ 2 %	NA	NA
FH output ⁴⁾	≤ 3 %	≤ 3 %	NA	NA
Long-term power drift ⁸⁾	± 2 %	± 1.5 %		
Beam spatial profile				
Beam diameter ¹⁰⁾	Super-Gaussian ⁹⁾ ~ 23 mm	Super-Gaussian ⁹⁾ ~ 7 mm	Super-Gaussian and Gaussian ⁹⁾ ~ 11 & 5 mm	Gaussian ⁹⁾ ~ 6 mm
Beam pointing stability ¹¹⁾	≤ 30 μrad	≤ 20 μrad	≤ 20 μrad	≤ 20 μrad
Beam divergence	≤ 0.5 mrad	≤ 0.5 mrad	≤ 0.5 mrad	≤ 0.5 mrad
Pre-pulse contrast ¹²⁾	> 200:1	> 200:1	> 200:1	> 200:1
Optical pulse jitter ¹³⁾				
Trig out	≤ 100 ps	≤ 100 ps	≤ 100 ps	≤ 50 ps
Pre-Trig out	≤ 50 ps	≤ 50 ps	≤ 50 ps	≤ 50 ps
With -PLL option	≤ 2 ps	≤ 2 ps	≤ 2 ps	NA
Polarization	Linear	Linear	Linear	Linear
PHYSICAL CHARACTERISTICS ¹⁴⁾				
Laser head size (W×L×H mm)	1500 × 3600 × 500, 2 pc.	1500 × 3600 × 500, 4 pc.	700 × 2000 × 300	900 × 1200 × 300
Power supply size (W×L×H mm)	553 × 600 × 1800, 4 pc.	553 × 600 × 1800, 4 pc.	553 × 952 × 600	553 × 952 × 600
Umbilical length ¹⁵⁾	5 m	2.5 m	2.5 m	3 m
OPERATING REQUIREMENTS ¹⁶⁾				
Electrical power	208, 380 or 400 VAC, three-phase, 50/60 Hz ¹⁷⁾	208, 380 or 400 VAC, three-phase, 50/60 Hz ¹⁷⁾	208 – 240 VAC, single-phase, 50/60 Hz	208 – 240 VAC, single-phase, 50/60 Hz
Power consumption ¹⁸⁾	≤ 40 kVA	≤ 60 kW	≤ 5 kW	≤ 3.5 kW
Water supply	≤ 40 l/min, 2 Bar, max 15 °C	≤ 40 l/min, 2 Bar, max 15 °C	≤ 5 l/min, 2 Bar, max 15 °C	≤ 15 l/min, 2 Bar, max 15 °C
Operating ambient temperature	22 ± 2 °C	22 ± 2 °C	22 ± 2 °C	22 ± 2 °C
Storage ambient temperature	15 – 35 °C	15 – 35 °C	15 – 35 °C	15 – 35 °C
Relative humidity (non-condensing)	≤ 80 %	≤ 80 %	≤ 80 %	≤ 80 %
Cleanness of the room	ISO Class 7	ISO Class 7	ISO Class 7	ISO Class 7

¹⁾ Due to continuous improvement, all specifications are subject to change without notice. The parameters marked 'typical' are indications of typical performance and will vary with each unit we manufacture. Presented parameters can be customized to meet customer's requirements. All parameters measured at 1064 nm if not stated otherwise.

²⁾ 2 200 mJ energy is achieved with Super-Gaussian spatial beam profile of 11th or higher order (with steep edges). If lower order Super-Gaussian is required maximum pulse energy will be limited to 2 000 mJ.

³⁾ 2 500 mJ output energy is available upon request with longer pulse duration.

⁴⁾ Harmonic outputs are optional. Specifications valid with respective harmonic module purchased. Outputs are not simultaneous.

⁵⁾ Second harmonic specification is valid when only SH option is ordered. If TH/FH options are orders second harmonic efficiency is reduced to ~50 %.

⁶⁾ Standard pulse duration is 90 ps. Other pulse durations can be ordered within range of 20 ps – 300 ps. Shortening the pulse duration below 90 ps will reduce the output energy proportionally.

⁷⁾ Under stable environmental conditions, normalized to average pulse energy (RMS, averaged from 60 s).



- 8) Measured over 8 hours period after 30 min warm-up when ambient temperature variation is less than ± 2 °C.
- 9) Super-Gaussian spatial mode of 6-11th order in near field.
- 10) Beam diameter is measured at signal output at 1/e² level for Gaussian beams and FWHM level for Super-Gaussian beams.
- 11) Beam pointing stability is evaluated as movement of the beam centroid in the focal plane of a focusing element (RMS, averaged from 60 s).
- 12) 1000:1 contrast available upon request.
- 13) Optical pulse jitter with respect to electrical outputs:
 - Trig out > 3.5 V @ 50 Ω
 - Pre-Trig out > 1 V @ 50 Ω
 - PLL option > 1 V @ 50 Ω
- 14) System sizes are preliminary and depend on customer lab layout and additional options purchased.
- 15) Longer umbilical with up to 10 m for flash lamp pumped and up to 5 m for diode pumped systems available upon request.
- 16) The laser and auxiliary units must be settled in such a place void of dust and aerosols. It is advisable to operate the laser in air conditioned room, provided that the laser is placed at a distance from air conditioning outlets. The laser should be positioned on a solid worktable. Access from one side should be ensured.
- 17) Voltage fluctuations allowed are +10 % / -15 % from nominal value.
- 18) Required current rating can be calculated by dividing power rating by mains voltage. Power rating is given in apparent power (kVA) for systems with flash lamp power supplies and in real power (kW) for systems without flash lamp power supplies where reactive power is neglectable.

OPTIONS

Option	Description	Comment
-P20...300	Custom pulse duration between 20 ps and 300 ps	Available with internal and external seeder. Shortening the pulse duration below 90 ps will reduce the output energy proportionally
-50/100	50 Hz or 100 Hz pulse repetition rate	Energy can be increased ~4 times compared to 1 kHz systems
-2k	2 kHz pulse repetition rate	Reduces the output energy of fundamental by ~50 %
-G	Gaussian like spatial beam profile	Reduces the output energy of fundamental by ~80 %
-FS	External seeder input via motorized spectral broadening stage	Requires > 1.5 nJ per pulse @ 800 nm, 100 fs
-PLL	Phase Lock Loop option for precise lock to external RF signal	Electrical to optical signal jitter \leq 3 ps
-SH/TH/FH	Second, third and fourth harmonic outputs	Conversion efficiency from fundamental respectively ~50 %, ~30 % and ~10 %. Harmonic outputs not simultaneous with fundamental output
-AW	Water-to-Air cooling	Replaces or supplements Water-to-Water cooling unit. Heat dissipation equals total power consumption

PERFORMANCE

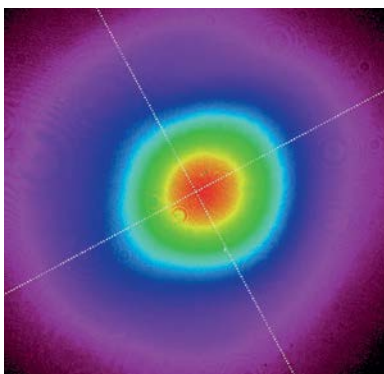

Fig 1. Typical PicoFlux Ytterbium system amplifier system near field beam profile at 1030 nm (imaged from laser output)

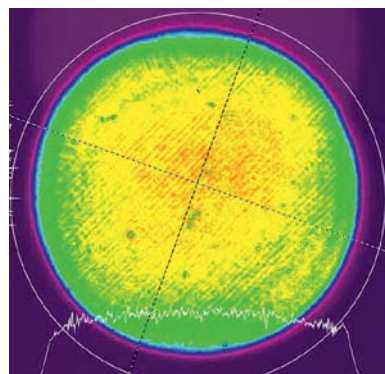

Fig 2. Typical High Energy PicoFlux amplifier system near field beam profile at 1064 nm (imaged from laser output)

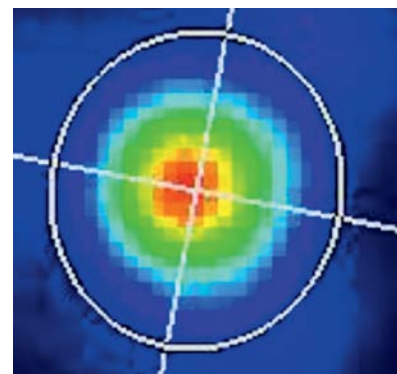

Fig 3. Typical High repetition rate PicoFlux amplifier system far field beam profile at 532 nm (imaged from SH crystal)

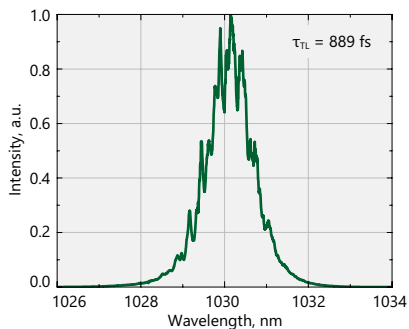

Fig 4. Typical output pulse spectrum of the PicoFlux Ytterbium system

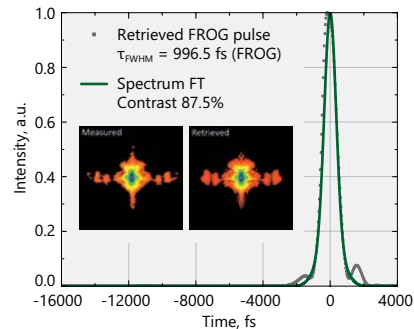

Fig 5. Typical pulse shape (FROG measurement) PicoFlux Ytterbium system

STABILITY

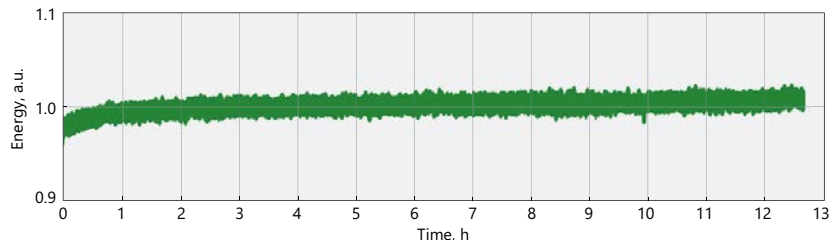

Fig 6. Typical long-term energy stability of High repetition rate PicoFlux system

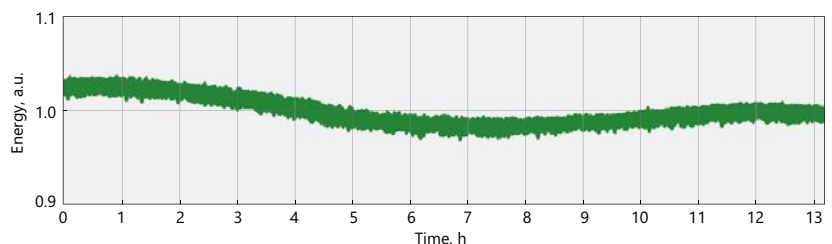

Fig 7. Typical long-term energy stability of High Energy PicoFlux system

ORDERING INFORMATION

Note: Laser must be connected to the mains electricity all the time. If there will be no mains electricity for longer than 1 hour then laser (system) needs warm up for a few hours before switching on.

PicoFlux P(1)(2)-x(3)-(4)

Energy level:
130 → 130 mJ
2k → 2200 mJ

Pulse repetition rate:
10 → 10 Hz
1k → 1 kHz

Any additional options:
See 'Options' table

Number of channels:
x4 → four channels
x8 → eight channels

Single Mode (SLM) High Energy Q-switched Nd:YAG Lasers

NanoFlux SLM SERIES



Typical external view of NanoFlux N2k10-SLM laser head (actual design might vary)

NanoFlux SLM series electro-optically Q-switched nanosecond Nd:YAG lasers deliver up to 10 J per pulse with excellent stability. These systems are an excellent choice for many applications, including OPO, OPCPA or dye laser pumping, holography, LIF spectroscopy, remote sensing, optics testing and other tasks.

The innovative, diode-pumped, self-seeded master oscillator design results in Single Longitudinal Mode (SLM) output without the use of external expensive narrow linewidth seed diodes and cavity-locking electronics. Unlike more common designs that use an unstable laser cavity, the stable master oscillator cavity produces a TEM₀₀ spatial mode output that results in excellent beam properties after the amplification stages. For tasks that require a smooth and as close as possible to the Gaussian beam profile, models with improved Gaussian fit are available.

NanoFlux series linear amplifiers are cost effective solution for high energy nanosecond systems. Advanced beam shaping ensures smooth, without hot spots beam spatial profile at the laser output. Low light depolarization level allows high efficiency generation

of up to 4th harmonic with optional build-in harmonic generators. The simple and field proven design ensures easy maintenance and reliable long-term operation of the NanoFlux SLM series laser.

Angle-tuned non-linear crystals harmonic generators mounted in temperature stabilized heaters are used for second, third and fourth harmonic generation. Harmonic separation system is designed to ensure high spectral purity of radiation and direct it to the output ports. Harmonic generators can be integrated into laser head or placed outside laser head into auxiliary harmonic generator module. Output wavelength switching is done manually. Motorized wavelength switching is available by request.

The low jitter of the optical pulse with respect to the Q-switch triggering pulse allows the reliable synchronization between the laser and external equipment.

System control is available through control pad, USB and LAN interfaces (RS232 as optional). The system can be controlled from personal computer with supplied software for Windows operating system.

FEATURES

- ▶ Up to **10 J** pulse energies
- ▶ **2 – 25 ns** pulse durations
- ▶ **10 Hz** pulse repetition rate
- ▶ Diode-pumped, self-seeded **Single Longitudinal Mode (SLM) master oscillator**
- ▶ Stable master oscillator cavity producing **TEM₀₀** spatial mode output
- ▶ **Excellent pulse energy stability**
- ▶ **Cost effective flash lamp pumped power amplifier**
- ▶ **Standard 2 ns** pulse duration (2 – 25 ns are optional)
- ▶ Temperature stabilized harmonics generator options
- ▶ Control through keypad, USB and LAN interfaces with supplied Windows control software (RS232 as optional)

APPLICATIONS

- ▶ Material processing
- ▶ OPO, OPCPA, Ti:Sapphire, dye laser pumping
- ▶ Holography
- ▶ Nonlinear laser spectroscopy
- ▶ Optics testing

SPECIFICATIONS

Model	N2k10-SLM	N5k10-SLM	N10k10-SLM
MAIN SPECIFICATIONS ¹⁾			
Output energy			
at 1064 nm	2 000 mJ	5 000 mJ	10 000 mJ
at 532 nm ^{2) 3)}	1 000 mJ	2 500 mJ	5 000 mJ
at 355 nm ²⁾	450 mJ	1 300 mJ	2 500 mJ
at 266 nm ²⁾	140 mJ	750 mJ	1 500 mJ
Pulse repetition rate	10 Hz	10 Hz	10 Hz
Pulse duration ⁴⁾	2 ± 0.5 ns	2 ± 0.5 ns	2 ± 0.5 ns
Pulse energy stability ⁵⁾			
at 1064 nm	≤ 0.8 %	≤ 0.8 %	≤ 0.8 %
at 532 nm	≤ 1.5 %	≤ 1.5 %	≤ 1.5 %
at 355 nm	≤ 3 %	≤ 3 %	≤ 3 %
at 266 nm	≤ 4 %	≤ 4 %	≤ 4 %
Long-term power drift ⁶⁾	± 2 %	± 2 %	± 2 %
Beam spatial profile ⁷⁾	Super-Gaussian	Super-Gaussian	Super-Gaussian
M ² ⁸⁾	4.4	6.6	9.2
Beam diameter ⁹⁾	~12 mm	~18 mm	~25 mm
Beam pointing stability ¹⁰⁾	≤ 25 µrad	≤ 25 µrad	≤ 25 µrad
Beam divergence	≤ 0.5 mrad	≤ 0.5 mrad	≤ 0.5 mrad
Optical pulse jitter ¹¹⁾	≤ 0.2 ns	≤ 0.2 ns	≤ 0.2 ns
Linewidth	≤ 0.01 cm ⁻¹ (SLM)	≤ 0.01 cm ⁻¹ (SLM)	≤ 0.01 cm ⁻¹ (SLM)
Polarization	linear, >90 %	linear, >90 %	linear, >90 %

PHYSICAL CHARACTERISTICS ¹²⁾			
Laser head size (W×L×H mm)	455 × 1220 × 270	600 × 1500 × 300	700 × 2000 × 300
Power supply size (W×L×H mm)	550 × 600 × 1030	550 × 600 × 1030 – 2 units	550 × 600 × 1650 – 2 units
Umbilical length ¹³⁾	5 m	5 m	5 m

OPERATING REQUIREMENTS ¹⁴⁾			
Power requirements ¹⁵⁾	208, 380 or 400 V AC, three phase, 50/60 Hz	208, 380 or 400 V AC, three phase, 50/60 Hz	208, 380 or 400 V AC, three phase, 50/60 Hz
Power consumption ¹⁶⁾	≤ 5 kVA	≤ 6 kVA	≤ 8 kVA
Water supply ¹⁶⁾	≤ 5 l/min, 2 Bar, max 15 °C	≤ 7 l/min, 2 Bar, max 15 °C	≤ 10 l/min, 2 Bar, max 15 °C
Operating ambient temperature	22 ± 2 °C	22 ± 2 °C	22 ± 2 °C
Storage ambient temperature	15 – 35 °C	15 – 35 °C	15 – 35 °C
Relative humidity (non-condensing)	≤ 80 %	≤ 80 %	≤ 80 %
Cleanness of the room	ISO Class 7	ISO Class 7	ISO Class 7

¹⁾ Due to continuous improvement, all specifications are subject to change without notice. The parameters marked 'typical' are indications of typical performance and will vary with each unit we manufacture. Presented parameters can be customized to meet customer's requirements. All parameters measured at 1064 nm if not stated otherwise.

²⁾ Harmonic outputs are optional. Specifications valid with respective harmonic module purchased. Outputs are not simultaneous.

³⁾ Second harmonic is available with LBO crystal then the conversion efficiency is increased to 70%. If TH/FH options are ordered second harmonic efficiency is reduced to ~50 %.

⁴⁾ Standard pulse duration is 2 ns. Other pulse durations can be ordered within range of 2 – 25 ns. Output energy might differ depending on duration.

⁵⁾ Under stable environmental conditions, normalized to average pulse energy (RMS, averaged from 60 s).

⁶⁾ Measured over 8 hours period after 30 min warm-up when ambient temperature variation is less than ±2 °C.

⁷⁾ Super-Gaussian spatial mode of 6-11th order in near field.

⁸⁾ The stated M² values are calculated using beam parameters. Actual measured value might differ.

⁹⁾ Beam diameter is measured at signal output at 1/e² level for Gaussian beams and FWHM level for Super-Gaussian beams.

¹⁰⁾ Beam pointing stability is evaluated as movement of the beam centroid in the focal plane of a focusing element (RMS, averaged from 60 s).

¹¹⁾ Optical pulse jitter with respect to electrical outputs: Trig out > 3.5 V @ 50 Ω.

¹²⁾ System sizes are preliminary and depend on customer lab layout and additional options purchased.

¹³⁾ Longer umbilical with up to 10 m available upon request.



¹⁴⁾ The laser and auxiliary units must be settled in such a place void of dust and aerosols. It is advisable to operate the laser in air conditioned room, provided that the laser is placed at a distance from air conditioning outlets. The laser should be positioned on a solid worktable. Access from one side should be ensured.

¹⁵⁾ Voltage fluctuations allowed are +10 % / -15 % from nominal value.

¹⁶⁾ Power consumption and water supply requirements deviate depending on system configuration.

OPTIONS

Option	Description	Comment
- G	Provides a Gaussian-like beam profile	Reduces the output energy of fundamental by ~80 %
- AW	Water-air cooling option	Replaces or supplements Water-to-Water cooling unit. Heat dissipation equals total power consumption
- N2...N25	Longer pulse duration option	In the range of 2 – 25 ns

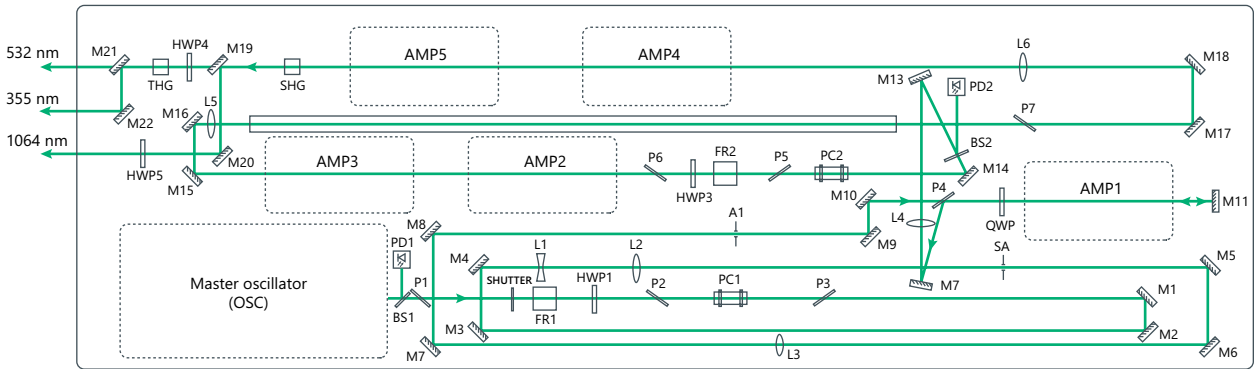

Fig 1. Principal optical layout of NanoFlux N10k10-SLM-SH-TH (actual layout might vary)

PERFORMANCE

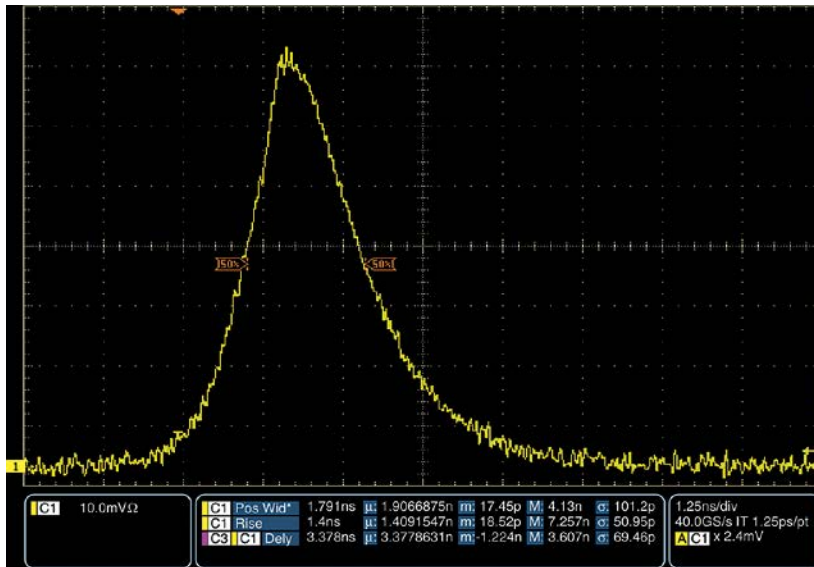

Fig 2. Typical temporal pulse shape of NanoFlux SLM system at 1064 nm

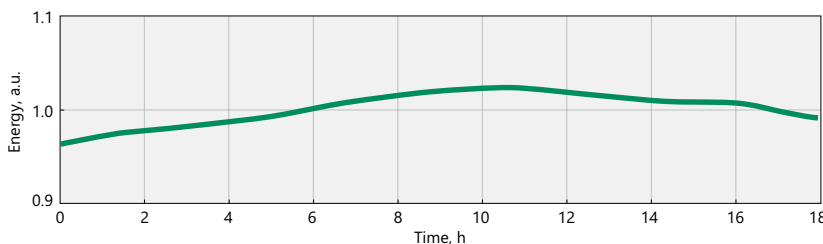

Fig 3. Typical long-term energy stability of High Energy NanoFlux system

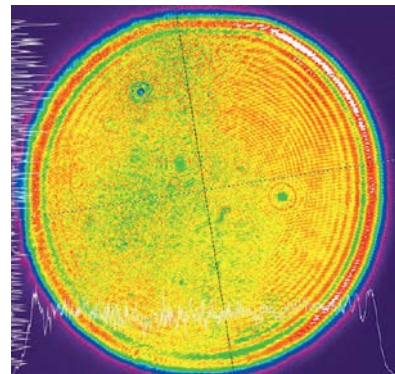

Fig 4. Typical beam profile of NanoFlux SLM laser system 50 cm from output at 1064 nm

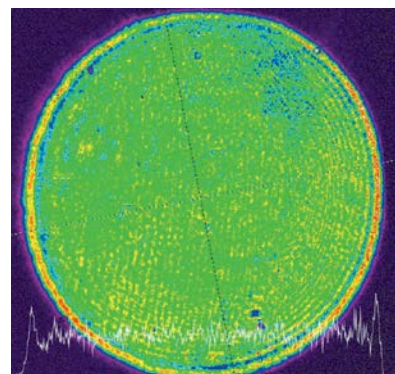

Fig 5. Typical beam profile of NanoFlux SLM laser system 30 cm from output at 532 nm

OUTLINE DRAWINGS



Fig 6. Typical external view of NanoFlux N10k10-SLM (actual design might vary)

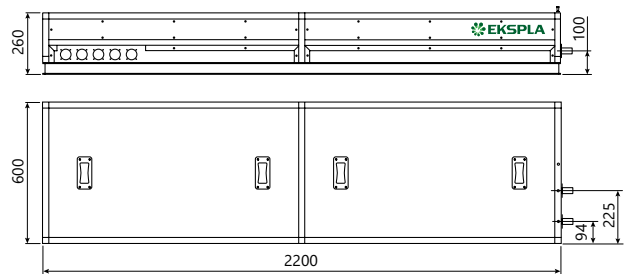

Fig 7. NanoFlux N10k10-SLM laser head outline drawing (actual dimensions might vary)

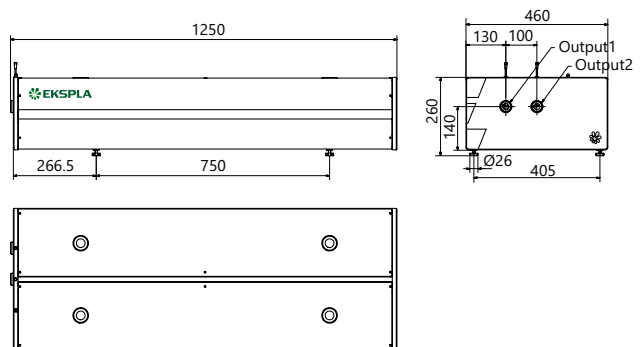

Fig 8. NanoFlux N2k10-SLM laser head outline drawing (actual dimensions might vary)

POWER SUPPLY

Cabinet	Usable height	Height H, mm	Width W, mm	Depth D, mm
MR-9	9 U	455.5 (519 ¹⁾)	553	600
MR-12	12 U	589 (653 ¹⁾)	553	600
MR-16	16 U	768 (832 ¹⁾)	553	600
MR-20	20 U	889 (952 ¹⁾)	553	600
MR-25	25 U	1167 (1231 ¹⁾)	553	600
MR-34	34 U	1640 (1709 ¹⁾)	553	600

¹⁾ Full height with wheels.

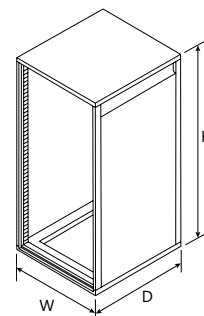

Fig 9. Typical NanoFlux SLM laser system power supply dimensions (MR rack used depends on the laser model)

ORDERING INFORMATION

Note: Laser must be connected to the mains electricity all the time. If there will be no mains electricity for longer than 1 hour then laser (system) needs warm up for a few hours before switching on.

NanoFlux N(1)(2)-SLM-(3)

Energy level:
2k → 2 J
5k → 5 J
10k → 10 J

Pulse repetition rate:
10 → 10 Hz

Any additional options:
See 'Options' table

Multimode (MM) High Energy Q-switched Nd:YAG Lasers

NanoFlux MM SERIES



Typical external view of NanoFlux N5k10 system (actual design might vary)

High energy NanoFlux MM series lasers are designed to produce high energy nanosecond pulses at 1064 nm. High pulse energy, excellent pulse-to-pulse energy stability, superior beam quality makes these systems well suited for applications like OPO or Ti: Sapphire pumping, material processing and plasma diagnostics and others.

NanoFlux MM series Q-switched oscillators are designed as extremely reliable and stable nanosecond seeding sources producing hundreds mJ pulses from a compact sized body. Simple access to critical compartments of the oscillator allows for easy maintenance. The higher M² version uses a pro-longed oscillator design that allows a much higher number of modes to oscillate which results in M² value up to 90. In this case the beam profile becomes very homogenous and flat which can be useful in a number of applications.

NanoFlux series linear amplifiers are cost effective solution for high energy nanosecond systems. Advanced beam shaping ensures smooth, without hot spots beam spatial profile at the laser output. Low light depolarization level allows high efficiency generation of up to 4th harmonic with optional

build-in harmonic generators. The simple and field proven design ensures easy maintenance and reliable long-term operation of the NanoFlux MM series laser.

Angle-tuned non-linear crystals harmonic generators mounted in temperature stabilized heaters are used for second, third and fourth harmonic generation. Harmonic separation system is designed to ensure high spectral purity of radiation and direct it to the output ports. Harmonic generators can be integrated into laser head or placed outside laser head into auxiliary harmonic generator module. Output wavelength switching is done manually. Motorized wavelength switching is available by request.

Triggering of the laser is possible from built-in internal or external pulse generator. Pulses with TTL levels are required for external triggering. Laser pulses have less than 0.5 ns RMS jitter with respect to Q-switch triggering pulse in both cases.

System control is available through control pad, USB and LAN interfaces (RS232 as optional). The system can be controlled from personal computer with supplied software for Windows operating system.

FEATURES

- ▶ High energy nanosecond lasers
- ▶ Up to **10 J** pulse energies
- ▶ **5 ns** pulse duration
- ▶ **Up to 20 ns** pulse duration options available
- ▶ **10 or 20 Hz** pulse repetition rate
- ▶ Better than **0.5% RMS** pulse energy stability
- ▶ Up to **90 M²** version available
- ▶ High efficiency pump chambers and advanced beam shaping for maximum pulse energy extraction
- ▶ Relay imaging between amplifier stages for smooth beam profile at the laser output
- ▶ Thermally induced birefringence compensated
- ▶ Optional temperature stabilized second, third, fourth and fifth harmonic generators
- ▶ Low jitter internal/external synchronization
- ▶ Robust and stable laser head
- ▶ Control through keypad, USB and LAN interfaces with supplied Windows control software (RS232 as optional)

APPLICATIONS

- ▶ OPO, Ti: Sapphire, dye laser pumping
- ▶ Material processing
- ▶ Plasma generation and diagnostics
- ▶ Nonlinear spectroscopy
- ▶ Remote sensing

SPECIFICATIONS

Model	N3k10	N5k10	N7k10	N10k10
MAIN SPECIFICATIONS ¹⁾				
Output energy				
at 1064 nm	3 000 mJ	5 000 mJ	7 000 mJ	10 000 mJ
at 532 nm ^{2) 3)}	1 500 mJ	2 500 mJ	3 500 mJ	5 000 mJ
at 355 nm ²⁾	1 000 mJ	1 300 mJ	1 700 mJ	2 000 mJ
at 266 nm ²⁾	270 mJ	400 mJ	500 mJ	700 mJ
Pulse repetition rate	10 Hz	10 Hz	10 Hz	10 Hz
Pulse duration ⁴⁾	5 ± 1 ns	5 ± 1 ns	5 ± 1 ns	5 ± 1 ns
Pulse energy stability ⁵⁾				
at 1064 nm	≤ 0.6 %	≤ 0.6 %	≤ 0.6 %	≤ 0.6 %
at 532 nm	≤ 1 %	≤ 1 %	≤ 1 %	≤ 1 %
at 355 nm	≤ 2 %	≤ 2 %	≤ 2 %	≤ 2 %
at 266 nm	≤ 3 %	≤ 3 %	≤ 3 %	≤ 3 %
Long-term power drift ⁶⁾	± 2 %	± 2 %	± 2 %	± 2 %
Beam spatial profile ⁷⁾	Super-Gaussian	Super-Gaussian	Super-Gaussian	Super-Gaussian
M ² ⁸⁾	~5	~5	~5	~5
Beam diameter ⁹⁾	~18 mm	~18 mm	~25 mm	~25 mm
Beam pointing stability ¹⁰⁾	≤ 50 µrad	≤ 50 µrad	≤ 50 µrad	≤ 50 µrad
Beam divergence	≤ 0.5 mrad	≤ 0.5 mrad	≤ 0.5 mrad	≤ 0.5 mrad
Optical pulse jitter ¹¹⁾	≤ 0.5 ns	≤ 0.5 ns	≤ 0.5 ns	≤ 0.5 ns
Linewidth	≤ 1 cm ⁻¹	≤ 1 cm ⁻¹	≤ 1 cm ⁻¹	≤ 1 cm ⁻¹
Polarization	Linear	Linear	Linear	Linear
PHYSICAL CHARACTERISTICS ¹²⁾				
Laser head size (W×L×H mm)	460 × 1250 × 260	500 × 1300 × 300	600 × 1800 × 300	700 × 2000 × 300
Power supply size (W×L×H mm)	550 × 600 × 1250	550 × 600 × 1250	550 × 600 × 1250	550 × 600 × 1640
Umbilical length ¹³⁾	5 m	5 m	5 m	5 m
OPERATING REQUIREMENTS ¹⁴⁾				
Power requirements ¹⁵⁾	208, 380 or 400 V AC, three phase, 50/60 Hz	208, 380 or 400 V AC, three phase, 50/60 Hz	208, 380 or 400 V AC, three phase, 50/60 Hz	208, 380 or 400 V AC, three phase, 50/60 Hz
Power consumption ¹⁶⁾	≤ 5 kVA	≤ 6 kVA	≤ 7 kVA	≤ 8 kVA
Water supply ¹⁶⁾	< 5 l/min, 2 Bar, max 15 °C	< 5 l/min, 2 Bar, max 15 °C	< 12 l/min, 2 Bar, max 15 °C	< 12 l/min, 2 Bar, max 15 °C
Operating ambient temperature	22 ± 2 °C	22 ± 2 °C	22 ± 2 °C	22 ± 2 °C
Storage ambient temperature	15 – 35 °C	15 – 35 °C	15 – 35 °C	15 – 35 °C
Relative humidity (non-condensing)	≤ 80 %	≤ 80 %	≤ 80 %	≤ 80 %
Cleanness of the room	ISO Class 7	ISO Class 7	ISO Class 7	ISO Class 7

¹⁾ Due to continuous improvement, all specifications are subject to change without notice. The parameters marked 'typical' are indications of typical performance and will vary with each unit we manufacture. Presented parameters can be customized to meet customer's requirements. All parameters measured at 1064 nm if not stated otherwise.

²⁾ Harmonic outputs are optional. Specifications valid with respective harmonic module purchased. Outputs are not simultaneous.

³⁾ Second harmonic is available with LBO crystal then the conversion efficiency is increased to 70%. If TH/FH options are orders second harmonic efficiency is reduced to ~50 %.

⁴⁾ Standard pulse duration is 5 ns. Other pulse durations can be ordered within range of 10 – 20 ns. Output energy might differ depending on duration.

⁵⁾ Under stable environmental conditions, normalized to average pulse energy (RMS, averaged from 60 s).

⁶⁾ Measured over 8 hours period after 30 min warm-up when ambient temperature variation is less than ±2 °C.

⁷⁾ Super-Gaussian spatial mode of 6-11th order in near field.

⁸⁾ M² value of ~5 is standard. Versions with M² in the range of 20 – 90 can be ordered.

⁹⁾ Beam diameter is measured at signal output at 1/e² level for Gaussian beams and FWHM level for Super-Gaussian beams.

¹⁰⁾ Beam pointing stability is evaluated as movement of the beam centroid in the focal plane of a focusing element (RMS, averaged from 60 s).

¹¹⁾ Optical pulse jitter with respect to electrical outputs: Trig out > 3.5 V @ 50 Ω.

¹²⁾ System sizes are preliminary and depend on customer lab layout and additional options purchased.

¹³⁾ Longer umbilical with up to 10 m available upon request.



¹⁴⁾ The laser and auxiliary units must be settled in such a place void of dust and aerosols. It is advisable to operate the laser in air conditioned room, provided that the laser is placed at a distance from air conditioning outlets. The laser should be positioned on a solid worktable. Access from one side should be ensured.

¹⁵⁾ Voltage fluctuations allowed are +10 % / -15 % from nominal value.

¹⁶⁾ Power consumption and water supply requirements deviate depending on system configuration.

OPTIONS

Option	Description	Comment
- G	Provides a Gaussian-like beam profile	Pulse energies are typically lower in comparison to standard version by 80 %
- M20...90	Provides a flat, smooth beam profile, without hot spots and diffraction rings in the near and medium field	$M^2 > 20$ or $M^2 > 90$
- RLI	Optional Relay Imaging for smooth beam profile	
- AW	Water-air cooling option	Replaces or supplements Water-to-Water cooling unit. Heat dissipation equals total power consumption
- N10...N20	10 – 20 ns pulse duration	

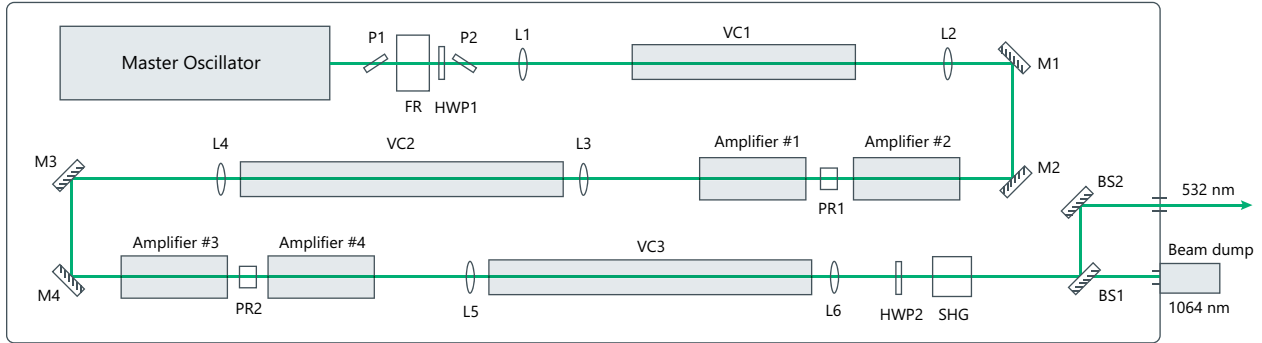

Fig 1. Principal optical layout of NanoFlux N10k10-SH (actual layout might vary)

PERFORMANCE

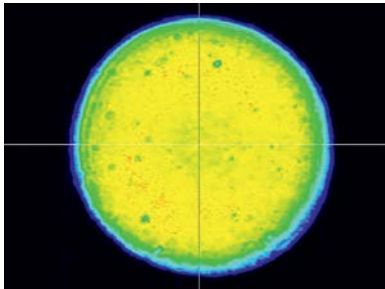

Fig 2. Typical beam profile of NanoFlux MM laser system at 1064 nm (imaged from amplifier exit)

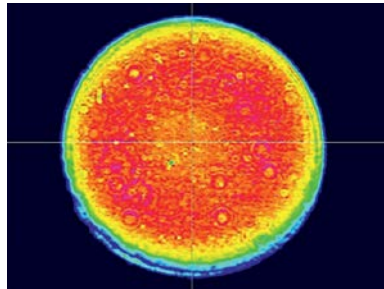

Fig 3. Typical beam profile of NanoFlux MM laser system at 532 nm (imaged from SH crystal)

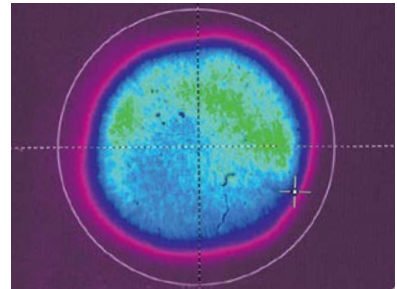

Fig 4. Typical beam profile of high M^2 version of NanoFlux MM laser system at 532 nm (imaged from SH crystal)

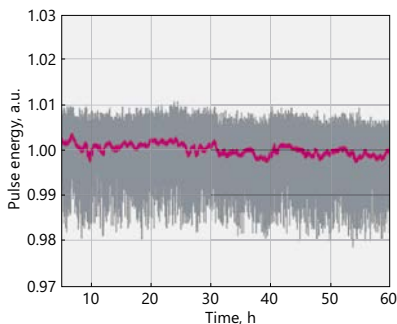

Fig 5. Typical long-term energy stability of High Energy NanoFlux system



Fig 6. Typical external view of NanoFlux N10k10-MM (actual design might vary)

OUTLINE DRAWINGS

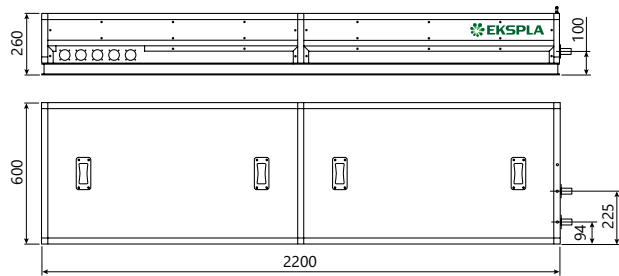

Fig 7. NanoFlux N7k10 or NanoFlux N10k10 laser head outline drawing (actual dimensions might vary)

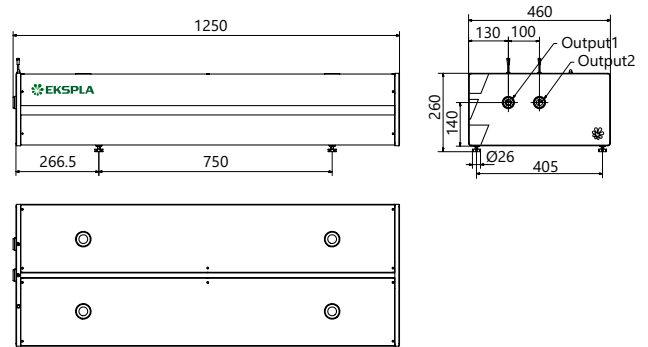

Fig 8. NanoFlux N3k10 or NanoFlux N5k10 laser head outline drawing (actual dimensions might vary)

POWER SUPPLY

Cabinet	Usable height	Height H, mm	Width W, mm	Depth D, mm
MR-9	9 U	455.5 (519 ¹⁾)	553	600
MR-12	12 U	589 (653 ¹⁾)	553	600
MR-16	16 U	768 (832 ¹⁾)	553	600
MR-20	20 U	889 (952 ¹⁾)	553	600
MR-25	25 U	1167 (1231 ¹⁾)	553	600
MR-34	34 U	1640 (1709 ¹⁾)	553	600

¹⁾ Full height with wheels.

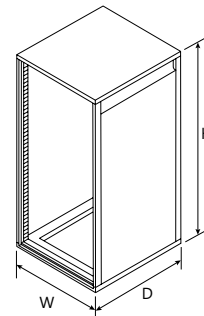

Fig 9. Typical NanoFlux laser system power supply dimensions (MR rack used depends on the laser model)

ORDERING INFORMATION

Note: Laser must be connected to the mains electricity all the time. If there will be no mains electricity for longer than 1 hour then laser (system) needs warm up for a few hours before switching on.

NanoFlux N(1)(2)-(3)

Energy level:
 2k → 2 J
 5k → 5 J
 7k → 7 J
 10k → 10 J

Any additional options:
 See 'Options' table

Pulse repetition rate:
 SS → Single Shot
 10 → 10 Hz

High Power Diode-Pumped Nanosecond Amplifier Systems

NanoFlux HP SERIES



Typical external view of NanoFlux DPSS series laser system (actual design might vary)

NanoFlux series electro-optically Q-switched nanosecond Nd:YAG amplifier systems produce high-energy pulses at high repetition rates. A diode-pumped Q-switched nanosecond laser, based on proven technology, serves as the system master oscillator. The pulses it produces are further amplified to the high-energy output pulses featuring a Super-Gaussian beam profile. The laser system master oscillator output pulses as short as several nanoseconds, featuring a uniform beam profile and low divergence. Alternatively, customers own seed source can be implemented as master oscillator and amplified to required energy level for further amplification in main power amplifiers. Power amplifiers are a chain of low-maintenance diode-pumped single and double pass amplifiers where pulses are amplified up to the required energy. During amplification, spatial beam shaping is employed in order to get a Super-Gaussian beam shape at the output.

Thermally stabilized angle-tuned harmonic generators assure stable second and third harmonic outputs. High spectral purity of harmonics output radiation is achieved using dichroic mirrors.

System control can be performed in several ways.

Using a laser system control pad, via USB and LAN ports (RS232 as optional), using a personal computer with supplied software for the Windows operating system. To tailor the laser for specific applications or requirements, a number of customization possibilities are available; e.g., an industrial-grade, portable laser housing with integrated power supplies and cooling units; customer's seed laser integration; multi-channel outputs; burst amplification, and others.

FEATURES

- ▶ Up to **5 J at 1064 nm** output pulse energy
- ▶ Up to **1 kHz** repetition rate
- ▶ **Multi-channel** version **2 J** per channel at 1064 nm
- ▶ Pulse durations **from 2 ns to 500 ns**
- ▶ Spatial Super-Gaussian beam profile
- ▶ Low maintenance cost and long diode lifetime
- ▶ Variable pulse duration and temporal pulse shape control (AWG) option available
- ▶ Various customization possibilities to tailor for specific application
- ▶ High efficiency diode pumping chambers
- ▶ Small laser head footprint and OEM integration upon request
- ▶ Internal system diagnostics
- ▶ Thermally induced birefringence compensation for high pulse repetition rates
- ▶ Integrated vacuum system for image translation for smooth Super-Gaussian beam profile
- ▶ **Burst** version available
- ▶ Optional thermally stabilized second and third harmonics generators
- ▶ Optional industrial grade, portable laser housing with integrated power supplies and cooling units

APPLICATIONS

- ▶ Thomson Scattering
- ▶ Multi-stage OPCPA pumping
- ▶ Non-linear optics
- ▶ Ti:S pumping

SPECIFICATIONS

Model	N400100	N5k100	N2001k	N2k100-Burst
MAIN SPECIFICATIONS ¹⁾				
Output energy				
at 1064 nm	400 mJ	5 000 mJ	200 mJ	2 000 mJ
at 532 nm ^{2) 3)}	260 mJ	3 000 mJ	130 mJ	1 300 mJ
at 355 nm ²⁾	120 mJ	Inquire	60 mJ	600 mJ
Pulse repetition rate	100 Hz	100 Hz	1 kHz	100 Hz
Pulse duration ⁴⁾	5 ± 1 ns	5 ± 1 ns	5 ± 1 ns	Adjustable bursts
Pulse energy stability ⁵⁾				
at 1064 nm	≤ 0.5 %	≤ 0.5 %	≤ 0.5 %	≤ 2 %
at 532 nm	≤ 0.8 %	≤ 0.8 %	≤ 0.8 %	≤ 4 %
at 355 nm	≤ 2 %	≤ 2 %	≤ 2 %	
Long-term power drift ⁶⁾	± 2 %	± 2 %	± 2 %	± 2 %
Beam spatial profile	Super-Gaussian ⁷⁾	Super-Gaussian ⁷⁾	Super-Gaussian ⁷⁾	Super-Gaussian ⁷⁾
Beam diameter ⁸⁾	7 mm	15 mm	7 mm	12 mm
Beam pointing stability ⁹⁾	≤ 30 µrad	≤ 30 µrad	≤ 30 µrad	≤ 30 µrad
Beam divergence	≤ 0.7 mrad	≤ 0.5 mrad	≤ 0.7 mrad	≤ 0.5 mrad
Optical pulse jitter ¹⁰⁾	≤ 0.2 ns	≤ 0.2 ns	≤ 0.2 ns	≤ 0.2 ns
Polarization	Linear	Linear	Linear	Linear
PHYSICAL CHARACTERISTICS ¹¹⁾				
Laser head size (W×L×H mm)	600×1200×300	900×2000×300	600×1200×300	900×1800×300
Power supply size (W×L×H mm)	553×600×830	553×600×1230	553×600×830	553×600×1800
Umbilical length ¹²⁾	2.5 m	2.5 m	2.5 m	2.5 m
OPERATING REQUIREMENTS ¹³⁾				
Power requirements ¹⁴⁾	208, 380 or 400 V AC, three phases, 50/60 Hz			
Power consumption ¹⁵⁾	≤ 6 kW	≤ 20 kW	≤ 10 kW	≤ 10 kW
Water supply ¹⁵⁾	≤ 8 l/min, 2 Bar, max 20 °C	≤ 20 l/min, 2 Bar, max 20 °C	≤ 12 l/min, 2 Bar, max 20 °C	≤ 12 l/min, 2 Bar, max 20 °C
Operating ambient temperature	22 ± 2 °C	22 ± 2 °C	22 ± 2 °C	22 ± 2 °C
Storage ambient temperature	15 – 35 °C	15 – 35 °C	15 – 35 °C	15 – 35 °C
Relative humidity (non-condensing)	≤ 80 %	≤ 80 %	≤ 80 %	≤ 80 %
Cleanliness of the room	ISO Class 7	ISO Class 7	ISO Class 7	ISO Class 7

¹⁾ Due to continuous improvement, all specifications are subject to change without notice. The parameters marked 'typical' are typical performance and vary with each unit we manufacture. These parameters can be customized to meet customers' requirements. All parameters measured at 1064 nm if not stated otherwise.

²⁾ Harmonic outputs are optional. Specifications are valid with the respective harmonic module purchased. Outputs are not simultaneous.

³⁾ Second harmonic specification is valid when only the SH option is ordered. If TH/FH options are ordered, second harmonic efficiency is reduced to ~50 %.

⁴⁾ Standard pulse duration is 5 ns. Other pulse durations can be ordered within the range of 0.2 – 500 ns. Output energy differs depending on duration.

⁵⁾ Under stable environmental conditions, normalized to average pulse energy (RMS, averaged from 60 s). Energy stability in burst mode depends on the temporal burst shape

⁶⁾ Measured after 30 min warm-up when the ambient temperature variation is less than ±2 °C during 8 hours.

⁷⁾ Super-Gaussian spatial mode of 6–11th order in near field.

⁸⁾ Beam diameter is measured at the laser output at the 1/e² level for Gaussian beams and the FWHM level for Super-Gaussian beams.

⁹⁾ Beam pointing stability is measured as the beam centroid movement in the focal plane of a focusing lens (RMS, averaged from 60 s).

¹⁰⁾ Optical pulse jitter with respect to electrical synchronization pulse outputs:
Trig out > 3.5 V @ 50 Ω.

¹¹⁾ System sizes are preliminary and depend on the customer's lab layout and options ordered.

¹²⁾ Longer umbilical with up to 5 m available upon request.

¹³⁾ The laser and auxiliary units must be settled in a place void of dust and aerosols. It is advisable to operate the laser in an air-conditioned room, provided that the laser is placed at a distance from air conditioning outlets. The laser should be positioned on a solid worktable. Access from one side should be ensured.

¹⁴⁾ Voltage fluctuations allowed are +10 % / -15 % from the nominal value.

¹⁵⁾ Power consumption and water supply requirements deviate depending on system configuration.



Note: The laser must be connected to the mains electricity at all times. If there will be no mains electricity for longer than 1 hour, then the laser (system) needs warm up for a few hours before switching on.

OPTIONS

Option	Description	Comment
- AWG	Arbitrary waveform generator	Temporal pulse shape control in 1 – 50 ns range by 125 ps step
- AW	Water-air cooling option	Replaces or supplements Water-to-Water cooling unit. Heat dissipation equals total power consumption
- External vacuum supply	External vacuum pump and tubing	
- Multiple channel option	Multiple outputs of same or different wavelength/energy	Up to 8 channels
- G	Gaussian like spatial beam profile	Reduces the output energy of fundamental by ~80 %

PERFORMANCE

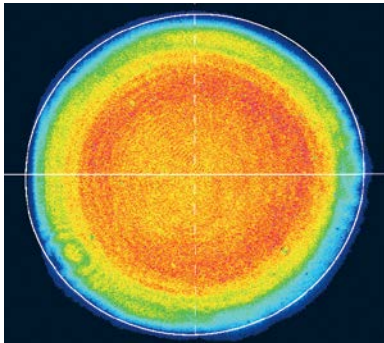

Fig 1. Typical NanoFlux DPSS system near field beam profile at 1064 nm

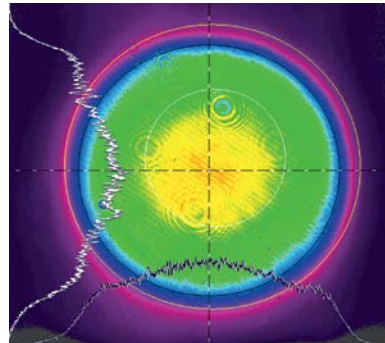

Fig 2. Typical NanoFlux DPSS system near field beam profile at 532 nm

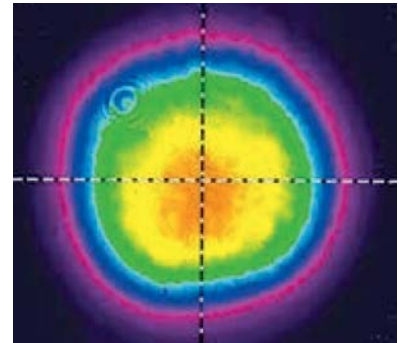

Fig 3. Typical NanoFlux DPSS system near field beam profile with Gaussian beam profile option purchased

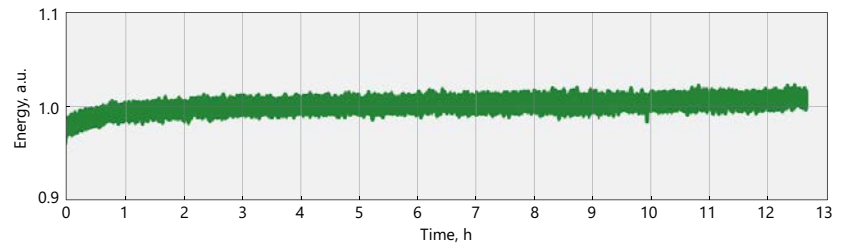

Fig 4. Typical long-term energy stability of High Power NanoFlux DPSS system

OUTLINE DRAWINGS

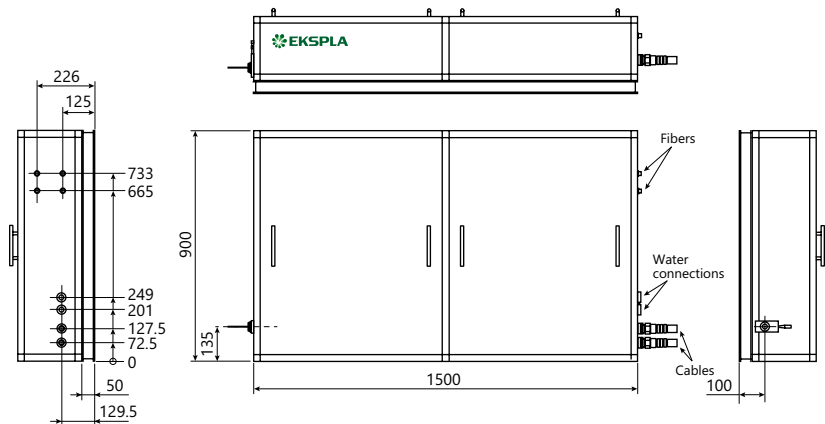

Fig 5. An example of NanoFlux DPSS system external dimensions

POWER SUPPLY

Cabinet	Usable height	Height H, mm	Width W, mm	Depth D, mm
MR-9	9 U	455.5 (519 ¹⁾)	553	600
MR-12	12 U	589 (653 ¹⁾)	553	600
MR-16	16 U	768 (832 ¹⁾)	553	600
MR-20	20 U	889 (952 ¹⁾)	553	600
MR-25	25 U	1167 (1231 ¹⁾)	553	600

¹⁾ Full height with wheels.

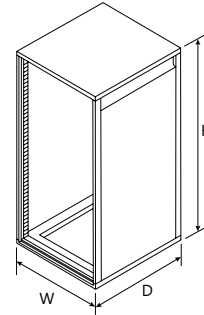

Fig 6. Typical NanoFlux laser system power supply dimensions (MR rack used depends on the laser model)

ORDERING INFORMATION

NanoFlux N(1)(2)-(3)

Energy level:
 200 → 200 mJ
 200 → 200 mJ
 2k → 2000 mJ
 5k → 5000 mJ

Any additional options:
 See 'Options' table

Pulse repetition rate:
 SS → Single Shot
 100 → 100 Hz
 1k → 1000 Hz

Temporally Shaped (AWG) High Energy Nd:YAG Lasers

NanoFlux AWG SERIES



Typical external view of NanoFlux N5k10-AWG-SH laser head

The main laser feature is the ability to shape output pulses temporally which is accomplished by an electro-optical modulator driven by programmable arbitrary waveform generator (AWG).

The front end of NanoFlux AWG laser system is comprised of a single-mode CW laser which is amplified in a fiber amplifier in the next step. Later on, AWG driven modulator transmits pulses of required temporal shape and duration which are further amplified diode pumped regenerative amplifier or all-in-fiber amplifier in order to reach energies sufficient to amplify in single-pass diode and flash lamp pumped amplifiers. Pulse shaping resolution is 125 ps, while maximum pulse length is 500 ns.

NanoFlux series linear amplifiers are convenient solution for high energy nanosecond systems where pulses are amplified in a chain of flash lamp pumped amplification units up to required energy. During amplification spatial beam shaping is used in order to get a flat top shaped beam profile without hot spots at the system output.

Angle-tuned non-linear crystals harmonic generators mounted in temperature stabilized heaters are used for second, third and fourth harmonic generation. Harmonic separation system is designed to ensure high spectral purity of radiation and direct it to the output ports.

FEATURES

- ▶ High energy nanosecond lasers
- ▶ Temporally shaped pulses
- ▶ Up to **10 J** pulse energies
- ▶ **10 Hz** pulse repetition rate
- ▶ Arbitrary waveform generator for pulse shaping
- ▶ **0.15 – 500 ns** adjustable pulse duration
- ▶ **Excellent pulse energy stability**
- ▶ **Cost effective** flash lamp pumped power amplifier
- ▶ Optional temperature stabilized harmonics options
- ▶ **Super-Gaussian** beam profile

APPLICATIONS

- ▶ OPCA pumping
- ▶ Front end for power amplifiers
- ▶ Ti:Sapphire pumping
- ▶ Laser peening – material hardening by laser-induced shock wave
- ▶ Plasma and shock physics

SPECIFICATIONS

Model	N2k10-AWG	N5k10-AWG	N10k10-AWG
MAIN SPECIFICATIONS ¹⁾			
Output energy ²⁾			
at 1064 nm	1 500 mJ	5 000 mJ	10 000 mJ (2 × 5 000 mJ) ³⁾
at 532 nm ^{4) 5)}	1 000 mJ	3 000 mJ	6 000 mJ
at 355 nm ⁴⁾	Inquire	Inquire	Inquire
Pulse repetition rate	10 Hz	10 Hz	10 Hz
Pulse duration ⁶⁾	0.15–20 ns	0.15–20 ns	0.15–20 ns
Pulse energy stability ⁷⁾			
at 1064 nm	≤ 0.5 %	≤ 0.5 %	≤ 0.5 %
at 532 nm	≤ 1 %	≤ 1 %	≤ 1 %
Long-term power drift ⁸⁾	± 2 %	± 2 %	± 2 %
Beam spatial profile ⁹⁾	Super-Gaussian	Super-Gaussian	Super-Gaussian
Beam diameter ¹⁰⁾	~11 mm	~25 mm	~25 mm
Beam pointing stability ¹¹⁾	≤ 50 µrad	≤ 50 µrad	≤ 50 µrad
Beam divergence	≤ 0.5 mrad	≤ 0.5 mrad	≤ 0.5 mrad
Optical pulse jitter ¹²⁾	< 50 ps	< 50 ps	< 50 ps
Linewidth	Single-mode	Single-mode	Single-mode
Polarization	Linear, > 90 %	Linear, > 90 %	Linear
PHYSICAL CHARACTERISTICS ¹³⁾			
Laser head size (W×L×H mm)	750 × 1350 × 300	700 × 2100 × 300	1000 × 2100 × 300
Power supply size (W×L×H mm)	550 × 600 × 840 – 1 unit 550 × 600 × 670 – 1 unit	550 × 600 × 1220 – 2 units	550 × 600 × 1220 – 2 units 550 × 600 × 670 – 1 unit
Umbilical length ¹⁴⁾	5 m	5 m	5 m
OPERATING REQUIREMENTS ¹⁵⁾			
Power requirements ¹⁶⁾	208, 380 or 400 V AC, three phases, 50/60 Hz	208, 380 or 400 V AC, three phases, 50/60 Hz	208, 380 or 400 V AC, three phases, 50/60 Hz
Power consumption ¹⁷⁾	≤ 6 kVA	≤ 9 kVA	≤ 13 kVA
Water supply ¹⁷⁾	≤ 5 l/min, 2 Bar, max 15 °C	≤ 8 l/min, 2 Bar, max 15 °C	≤ 12 l/min, 2 Bar, max 15 °C
Operating ambient temperature	22 ± 2 °C	22 ± 2 °C	22 ± 2 °C
Storage ambient temperature	15 – 35 °C	15 – 35 °C	15 – 35 °C
Relative humidity (non-condensing)	≤ 80 %	≤ 80 %	≤ 80 %
Cleanness of the room	ISO Class 7	ISO Class 7	ISO Class 7

¹⁾ Due to continuous improvement, all specifications are subject to change without notice. The parameters marked 'typical' are indications of typical performance and will vary with each unit we manufacture. Presented parameters can be customized to meet customer's requirements. All parameters measured at 1064 nm if not stated otherwise.

²⁾ The output energies are measured at 5 ns, rectangular pulse at time domain, FWHM.

³⁾ The 10 J energy output is combined of two 5 J channels with vertical and horizontal polarizations.

⁴⁾ Harmonic outputs are optional. Specifications valid with respective harmonic module purchased. Outputs are not simultaneous.

⁵⁾ Second harmonic is available with LBO crystal then the conversion efficiency is increased to 70%. If TH/FH options are orders second harmonic efficiency is reduced to ~50 %.

⁶⁾ Variable pulse duration in steps of 125 ps. Standard pulse duration adjustability is between 1-20 ns. Shorter or longer pulse durations are optional. Pulse shaping is possible in the range of 1 – 500 ns.

⁷⁾ Under stable environmental conditions, normalized to average pulse energy (RMS, averaged from 60 s).

⁸⁾ Measured over 8 hours period after 30 min warm-up when ambient temperature variation is less than ±2 °C.

⁹⁾ Super-Gaussian spatial mode of 6-11th order in near field.

¹⁰⁾ Beam diameter is measured at signal output at 1/e² level for Gaussian beams and FWHM level for Super-Gaussian beams.

¹¹⁾ Beam pointing stability is evaluated as movement of the beam centroid in the focal plane of a focusing element (RMS, averaged from 60 s).

¹²⁾ Optical pulse jitter with respect to electrical outputs: Trig out > 3.5 V @ 50 Ω.

¹³⁾ System sizes are preliminary and depend on customer lab layout and additional options purchased.

¹⁴⁾ Longer umbilical with up to 10 m available upon request.

¹⁵⁾ The laser and auxiliary units must be settled in such a place void of dust and aerosols. It is advisable to operate the laser in air conditioned room, provided that the laser is placed at a distance from air conditioning outlets. The laser should be positioned on a solid worktable. Access from one side should be ensured.

¹⁶⁾ Voltage fluctuations allowed are +10 % / -15 % from nominal value.

¹⁷⁾ Power consumption and water supply requirements deviate depending on system configuration.



OPTIONS

Option	Description	Comment
- G	Provides a Gaussian-like beam profile	Pulse energies are typically lower in comparison to standard version by 80%
- AW	Water-air cooling unit or chiller	
- N20...N500	Extended AWG pulse durations	Output energies (especially for SHG output) are specified for one pulse duration with square temporal pulse shape

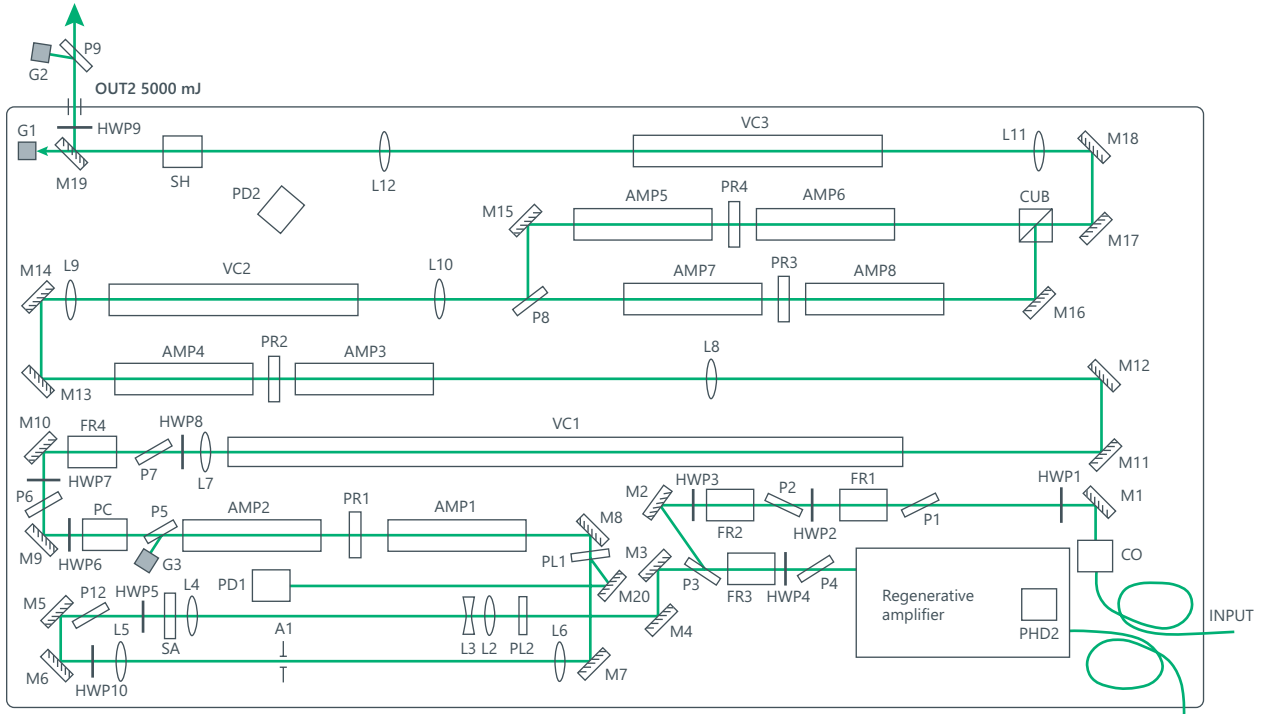

Fig 1. Principal optical layout of NanoFlux N10k10-AWG-SH (actual layout might vary)

PERFORMANCE

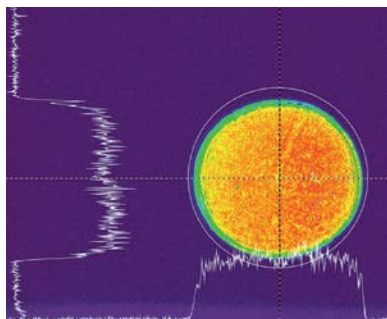

Fig 2. Typical beam profile of NanoFlux AWG laser system at 532 nm (imaged from SH crystal plane)

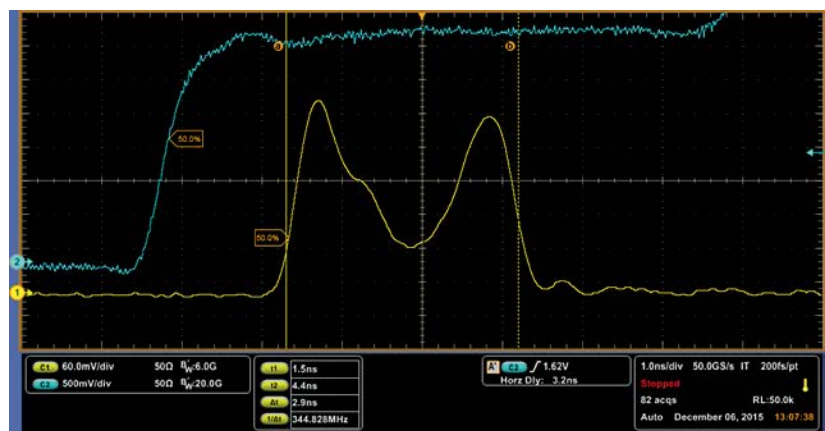

Fig 3. Temporally M shaped pulse (yellow line)

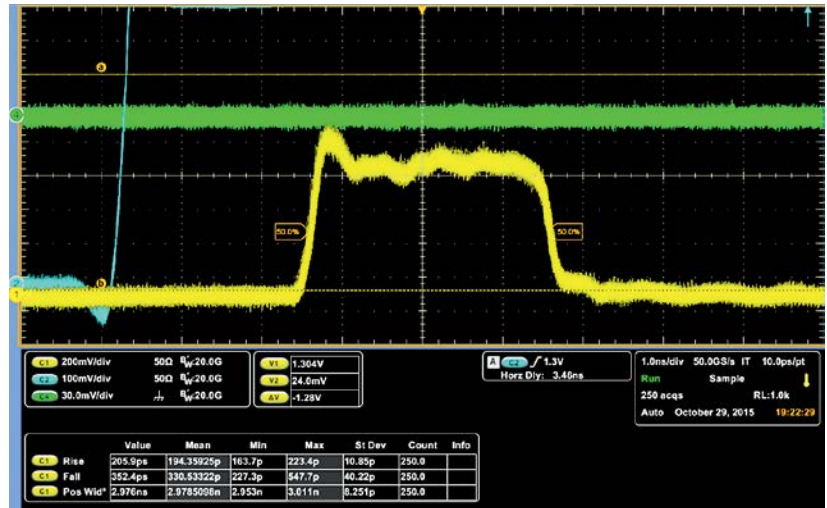

Fig 4. Temporally square shaped pulse (yellow line)

OUTLINE DRAWINGS

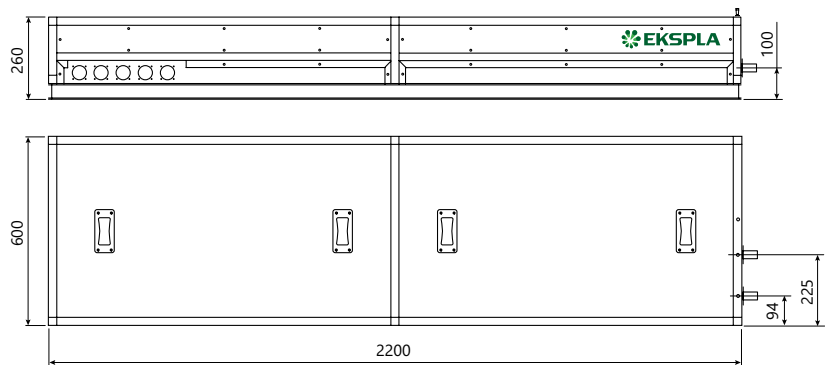

Fig 5. NanoFlux N10k10-AWG laser head outline drawing (actual dimensions might vary)

POWER SUPPLY

Cabinet	Usable height	Height H, mm	Width W, mm	Depth D, mm
MR-9	9 U	455.5 (519 ¹⁾)	553	600
MR-12	12 U	589 (653 ¹⁾)	553	600
MR-16	16 U	768 (832 ¹⁾)	553	600
MR-20	20 U	889 (952 ¹⁾)	553	600
MR-25	25 U	1167 (1231 ¹⁾)	553	600
MR-34	34 U	1640 (1709 ¹⁾)	553	600

¹⁾ Full height with wheels.

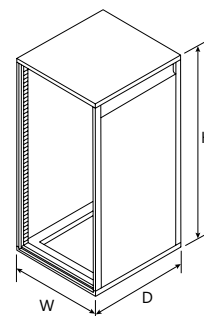

Fig 6. Typical NanoFlux AWG laser system power supply dimensions (MR rack used depends on the laser model)

ORDERING INFORMATION

Note: Laser must be connected to the mains electricity all the time. If there will be no mains electricity for longer than 1 hour then laser (system) needs warm up for a few hours before switching on.

NanoFlux N(1)(2)-AWG-(3)

Energy level:
 2k → 2 J
 5k → 5 J
 10k → 10 J

Any additional options:
 See 'Options' table

Pulse repetition rate:
 SS → Single Shot
 10 → 10 Hz

Ordering Information

Delivery	Products are made and dispatched within agreed term. Shipping charges are object of agreement between EKSPILA and customer.
Ordering	Orders may be placed by mail, fax or e-mail. All orders are object of General Sales Conditions, which can be found on www.ekspla.com . Mail orders should be sent to: EKSPILA, UAB Savanoriu Av. 237 LT-02300 Vilnius Lithuania Phone: +370 5 264 96 29 E-mail: sales@ekspla.com Ask for quotation online at www.ekspla.com.
Certificate of Origin	All items shown in this catalogue are of Lithuanian Origin (EU). Certificate of Origin is available under request.
Warranty	All products are guaranteed to be free from defects in material and workmanship. The warranty period depends on the product and is object of agreement between EKSPILA and customer. Warranty period can be extended by separate agreement. EKSPILA does not assume liability for improper installation, labor or consequential damages.
Specifications	Due to the constant product improvements, EKSPILA reserves its right to change specifications without advance notice.

For latest information visit www.ekspla.com.



グローバルにネットワークを広げ、最先端の科学をお客様に提供

本社: 〒134-0088 東京都江戸川区西葛西6-18-14 T.I.ビル Tel. 03-3686-4711

営業所: 〒532-0003 大阪府大阪市淀川区宮原4-1-46 新大阪北ビル Tel. 06-6393-7411

URL: <https://www.tokyoinst.co.jp> Mail: sales@tokyoinst.co.jp



超高真空・極低温走査型プローブ顕微鏡
高速分光測定装置、クライオスタット



Nd:YAGレーザー、Ti:Sレーザー
OPOLレーザー



Follow us on Linked 



ISO9001 Certified

Find local distributor at
www.ekspla.com



Savanorių Av. 237
LT-02300 Vilnius
Lithuania

ph. +370 5 264 96 29
sales@ekspla.com
www.ekspla.com