

Single Mode (SLM) High Energy Q-switched Nd:YAG Lasers

NanoFlux SLM SERIES



Typical external view of NanoFlux N2k10-SLM laser head (actual design might vary)

NanoFlux SLM series electro-optically Q-switched nanosecond Nd:YAG lasers deliver up to 10 J per pulse with excellent stability. These systems are an excellent choice for many applications, including OPO, OPCPA or dye laser pumping, holography, LIF spectroscopy, remote sensing, optics testing and other tasks.

The innovative, diode-pumped, self-seeded master oscillator design results in Single Longitudinal Mode (SLM) output without the use of external expensive narrow linewidth seed diodes and cavity-locking electronics. Unlike more common designs that use an unstable laser cavity, the stable master oscillator cavity produces a TEM_{00} spatial mode output that results in excellent beam properties after the amplification stages. For tasks that require a smooth and as close as possible to the Gaussian beam profile, models with improved Gaussian fit are available.

NanoFlux series linear amplifiers are cost effective solution for high energy nanosecond systems. Advanced beam shaping ensures smooth, without hot spots beam spatial profile at the laser output. Low light depolarization level allows high efficiency generation

of up to 4th harmonic with optional build-in harmonic generators. The simple and field proven design ensures easy maintenance and reliable long-term operation of the NanoFlux SLM series laser.

Angle-tuned non-linear crystals harmonic generators mounted in temperature stabilized heaters are used for second, third and fourth harmonic generation. Harmonic separation system is designed to ensure high spectral purity of radiation and direct it to the output ports. Harmonic generators can be integrated into laser head or placed outside laser head into auxiliary harmonic generator module. Output wavelength switching is done manually. Motorized wavelength switching is available by request.

The low jitter of the optical pulse with respect to the Q-switch triggering pulse allows the reliable synchronization between the laser and external equipment.

System control is available through control pad, USB and LAN interfaces (RS232 as optional). The system can be controlled from personal computer with supplied software for Windows operating system.

FEATURES

- ▶ Up to **10 J** pulse energies
- ▶ **2 – 25 ns** pulse durations
- ▶ **10 Hz** pulse repetition rate
- ▶ Diode-pumped, self-seeded **Single Longitudinal Mode (SLM) master oscillator**
- ▶ Stable master oscillator cavity producing **TEM_{00}** spatial mode output
- ▶ **Excellent pulse energy stability**
- ▶ **Cost effective flash lamp pumped power amplifier**
- ▶ **Standard 2 ns** pulse duration (2 – 25 ns are optional)
- ▶ Temperature stabilized harmonics generator options
- ▶ Control through keypad, USB and LAN interfaces with supplied Windows control software (RS232 as optional)

APPLICATIONS

- ▶ Material processing
- ▶ OPO, OPCPA, Ti:Sapphire, dye laser pumping
- ▶ Holography
- ▶ Nonlinear laser spectroscopy
- ▶ Optics testing

SPECIFICATIONS

Model	N2k10-SLM	N5k10-SLM	N10k10-SLM
MAIN SPECIFICATIONS ¹⁾			
Output energy			
at 1064 nm	2 000 mJ	5 000 mJ	10 000 mJ
at 532 nm ^{2) 3)}	1 000 mJ	2 500 mJ	5 000 mJ
at 355 nm ²⁾	450 mJ	1 300 mJ	2 500 mJ
at 266 nm ²⁾	140 mJ	750 mJ	1 500 mJ
Pulse repetition rate	10 Hz	10 Hz	10 Hz
Pulse duration ⁴⁾	2 ± 0.5 ns	2 ± 0.5 ns	2 ± 0.5 ns
Pulse energy stability ⁵⁾			
at 1064 nm	≤ 0.8 %	≤ 0.8 %	≤ 0.8 %
at 532 nm	≤ 1.5 %	≤ 1.5 %	≤ 1.5 %
at 355 nm	≤ 3 %	≤ 3 %	≤ 3 %
at 266 nm	≤ 4 %	≤ 4 %	≤ 4 %
Long-term power drift ⁶⁾	± 2 %	± 2 %	± 2 %
Beam spatial profile ⁷⁾	Super-Gaussian	Super-Gaussian	Super-Gaussian
M ² ⁸⁾	4.4	6.6	9.2
Beam diameter ⁹⁾	~12 mm	~18 mm	~25 mm
Beam pointing stability ¹⁰⁾	≤ 25 µrad	≤ 25 µrad	≤ 25 µrad
Beam divergence	≤ 0.5 mrad	≤ 0.5 mrad	≤ 0.5 mrad
Optical pulse jitter ¹¹⁾	≤ 0.2 ns	≤ 0.2 ns	≤ 0.2 ns
Linewidth	≤ 0.01 cm ⁻¹ (SLM)	≤ 0.01 cm ⁻¹ (SLM)	≤ 0.01 cm ⁻¹ (SLM)
Polarization	linear, >90 %	linear, >90 %	linear, >90 %

PHYSICAL CHARACTERISTICS ¹²⁾			
Laser head size (W×L×H mm)	455 × 1220 × 270	600 × 1500 × 300	700 × 2000 × 300
Power supply size (W×L×H mm)	550 × 600 × 1030	550 × 600 × 1030 – 2 units	550 × 600 × 1650 – 2 units
Umbilical length ¹³⁾	5 m	5 m	5 m

OPERATING REQUIREMENTS ¹⁴⁾			
Power requirements ¹⁵⁾	208, 380 or 400 V AC, three phase, 50/60 Hz	208, 380 or 400 V AC, three phase, 50/60 Hz	208, 380 or 400 V AC, three phase, 50/60 Hz
Power consumption ¹⁶⁾	≤ 5 kVA	≤ 6 kVA	≤ 8 kVA
Water supply ¹⁶⁾	≤ 5 l/min, 2 Bar, max 15 °C	≤ 7 l/min, 2 Bar, max 15 °C	≤ 10 l/min, 2 Bar, max 15 °C
Operating ambient temperature	22 ± 2 °C	22 ± 2 °C	22 ± 2 °C
Storage ambient temperature	15 – 35 °C	15 – 35 °C	15 – 35 °C
Relative humidity (non-condensing)	≤ 80 %	≤ 80 %	≤ 80 %
Cleanness of the room	ISO Class 7	ISO Class 7	ISO Class 7

¹⁾ Due to continuous improvement, all specifications are subject to change without notice. The parameters marked 'typical' are indications of typical performance and will vary with each unit we manufacture. Presented parameters can be customized to meet customer's requirements. All parameters measured at 1064 nm if not stated otherwise.

²⁾ Harmonic outputs are optional. Specifications valid with respective harmonic module purchased. Outputs are not simultaneous.

³⁾ Second harmonic is available with LBO crystal then the conversion efficiency is increased to 70%. If TH/FH options are ordered second harmonic efficiency is reduced to ~50 %.

⁴⁾ Standard pulse duration is 2 ns. Other pulse durations can be ordered within range of 2 – 25 ns. Output energy might differ depending on duration.

⁵⁾ Under stable environmental conditions, normalized to average pulse energy (RMS, averaged from 60 s).

⁶⁾ Measured over 8 hours period after 30 min warm-up when ambient temperature variation is less than ±2 °C.

⁷⁾ Super-Gaussian spatial mode of 6-11th order in near field.

⁸⁾ The stated M² values are calculated using beam parameters. Actual measured value might differ.

⁹⁾ Beam diameter is measured at signal output at 1/e² level for Gaussian beams and FWHM level for Super-Gaussian beams.

¹⁰⁾ Beam pointing stability is evaluated as movement of the beam centroid in the focal plane of a focusing element (RMS, averaged from 60 s).

¹¹⁾ Optical pulse jitter with respect to electrical outputs: Trig out > 3.5 V @ 50 Ω.

¹²⁾ System sizes are preliminary and depend on customer lab layout and additional options purchased.

¹³⁾ Longer umbilical with up to 10 m available upon request.



¹⁴⁾ The laser and auxiliary units must be settled in such a place void of dust and aerosols. It is advisable to operate the laser in air conditioned room, provided that the laser is placed at a distance from air conditioning outlets. The laser should be positioned on a solid worktable. Access from one side should be ensured.

¹⁵⁾ Voltage fluctuations allowed are +10 % / -15 % from nominal value.

¹⁶⁾ Power consumption and water supply requirements deviate depending on system configuration.

OPTIONS

Option	Description	Comment
- G	Provides a Gaussian-like beam profile	Reduces the output energy of fundamental by ~80 %
- AW	Water-air cooling option	Replaces or supplements Water-to-Water cooling unit. Heat dissipation equals total power consumption
- N2...N25	Longer pulse duration option	In the range of 2 – 25 ns

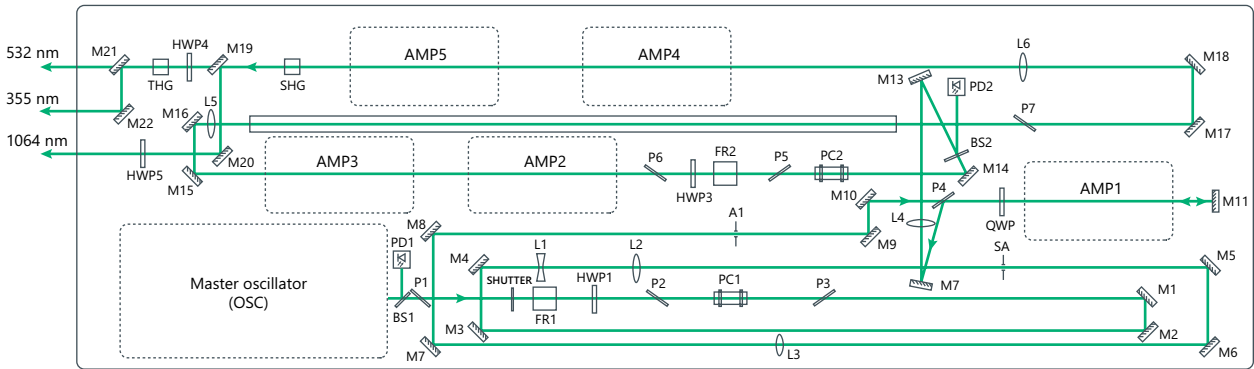

Fig 1. Principal optical layout of NanoFlux N10k10-SLM-SH-TH (actual layout might vary)

PERFORMANCE

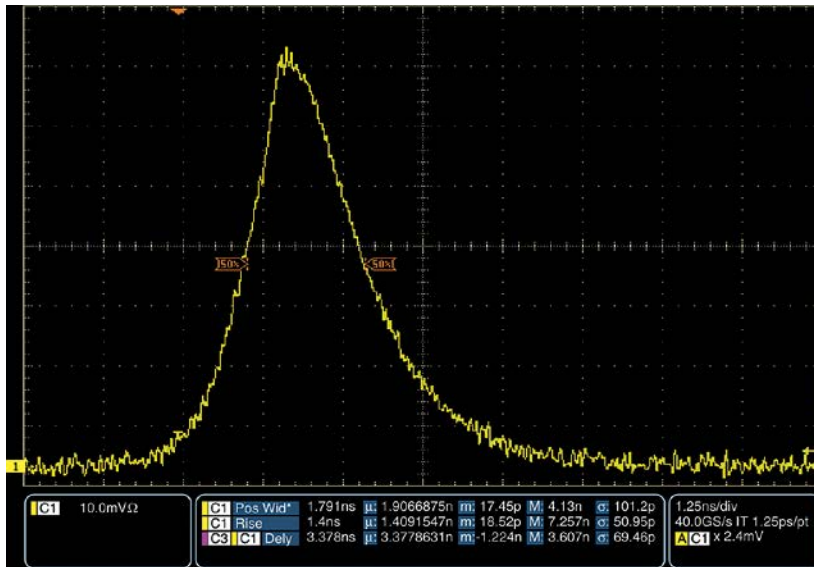

Fig 2. Typical temporal pulse shape of NanoFlux SLM system at 1064 nm

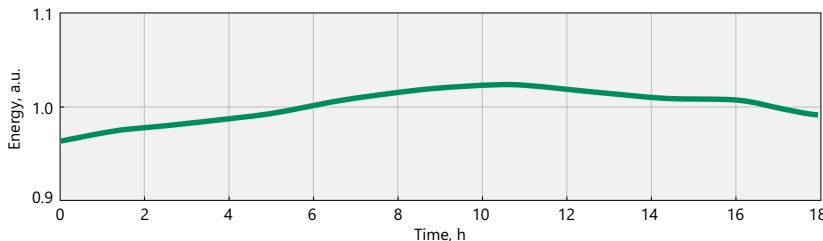

Fig 3. Typical long-term energy stability of High Energy NanoFlux system

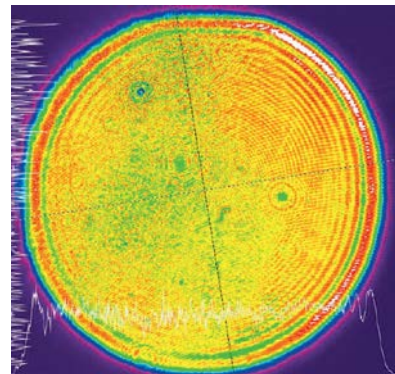

Fig 4. Typical beam profile of NanoFlux SLM laser system 50 cm from output at 1064 nm

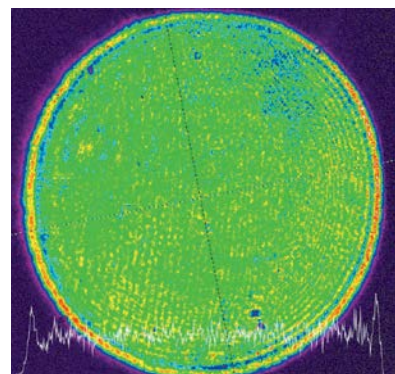

Fig 5. Typical beam profile of NanoFlux SLM laser system 30 cm from output at 532 nm

OUTLINE DRAWINGS



Fig 6. Typical external view of NanoFlux N10k10-SLM (actual design might vary)

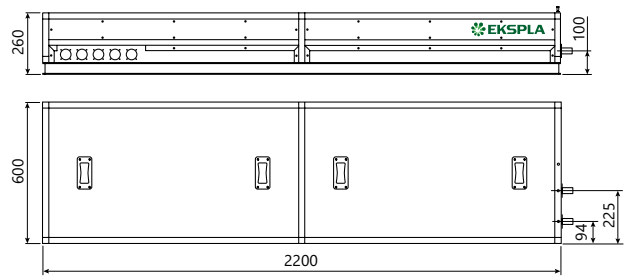

Fig 7. NanoFlux N10k10-SLM laser head outline drawing (actual dimensions might vary)

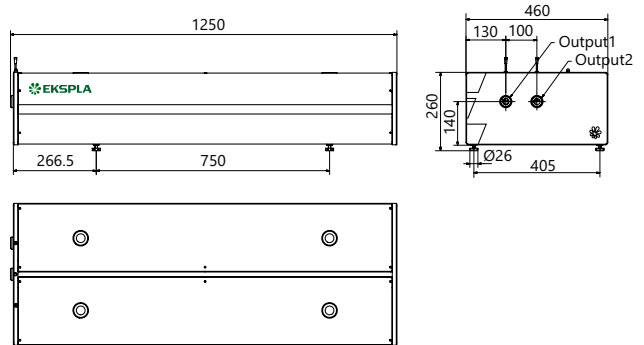

Fig 8. NanoFlux N2k10-SLM laser head outline drawing (actual dimensions might vary)

POWER SUPPLY

Cabinet	Usable height	Height H, mm	Width W, mm	Depth D, mm
MR-9	9 U	455.5 (519 ¹⁾)	553	600
MR-12	12 U	589 (653 ¹⁾)	553	600
MR-16	16 U	768 (832 ¹⁾)	553	600
MR-20	20 U	889 (952 ¹⁾)	553	600
MR-25	25 U	1167 (1231 ¹⁾)	553	600
MR-34	34 U	1640 (1709 ¹⁾)	553	600

¹⁾ Full height with wheels.

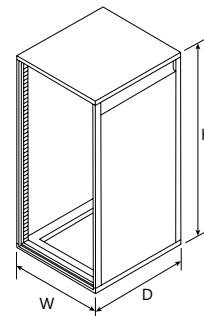

Fig 9. Typical NanoFlux SLM laser system power supply dimensions (MR rack used depends on the laser model)

ORDERING INFORMATION

Note: Laser must be connected to the mains electricity all the time. If there will be no mains electricity for longer than 1 hour then laser (system) needs warm up for a few hours before switching on.

NanoFlux N(1)(2)-SLM-(3)

Energy level:
2k → 2 J
5k → 5 J
10k → 10 J

Any additional options:
See 'Options' table
Pulse repetition rate:
10 → 10 Hz



グローバルにネットワークを広げ、最先端の科学をお客様に提供

本社: 〒134-0088 東京都江戸川区西葛西6-18-14 T.ビル Tel. 03-3686-4711
営業所: 〒532-0003 大阪府大阪市淀川区宮原4-1-46 新大阪北ビル Tel. 06-6393-7411
URL: <https://www.tokyoinst.co.jp> Mail: sales@tokyoinst.co.jp

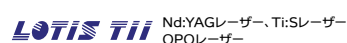
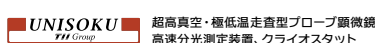

- 本カタログに記載されている内容は、改良のため予告無く変更する場合があります。(製品の仕様、性能、価格などはカタログ発行当時のものです)
- 本カタログに記載されている内容の一部または全部を無断で転載することは禁止されています。
- 本カタログに記載されているメーカー名、製品名などは各社の商標または登録商標です。